

Sentinel LNG

Panametrics ultrasonic flow meter for cryogenic liquids

Panametrics introduces Sentinel LNG, a new addition to our series of advanced ultrasonic flow meters. Sentinel LNG demonstrates new levels of performance, reacts to changes in flow rate with incredible speed and accuracy, and is based on proven technologies. Sentinel LNG extends the use of ultrasonic technology into cryogenic applications for measuring liquefied natural gas (LNG) with unbeatable performance, reliability and safety.

Sentinel LNG design

The design philosophy behind Sentinel LNG was simple; building a reliable flow meter to overcome the accuracy limitation of LNG tank level measurement. Sentinel LNG is an ultrasonic flow meter with a fully welded construction that has no moving parts. The acoustic transducers are placed outside the cryogenic liquid to avoid any long-term degradation due to temperature. The design is full bore; as a result, the pressure drop over the meter is simply equal to a section of pipe with the same length.

Advanced electronics

Sentinel LNG measures flow using advanced digital-signal processing and improved algorithms that enable the meter to measure flow with an exceptional response speed. Sentinel LNG packs significant power in a simple package available with several standard output options. Customer wiring is kept in a separate location for safety. It can be mounted on the flowcell section or can be mounted up to 50 ft (15 m) away. Full access to cable connections is still possible even when mounted directly to a wall. Full diagnostic capability can be checked locally on the display, remotely by PC or output via a variety of digital interfaces for continuous verification and preventative maintenance.

Robust path configuration™

Before Sentinel LNG was ever tested on a calibration loop, the meter was already extensively tested in the virtual world. Computational Fluid Dynamics (CFD) was used to simulate different path configurations under different flow scenarios. CFD allowed us to test different ultrasonic path configurations under highly turbulent flow regimes that are typically seen in LNG measurements. Only after CFD simulation provided the optimal path configuration, Sentinel LNG was tested in a calibration loop to prove the CFD results.

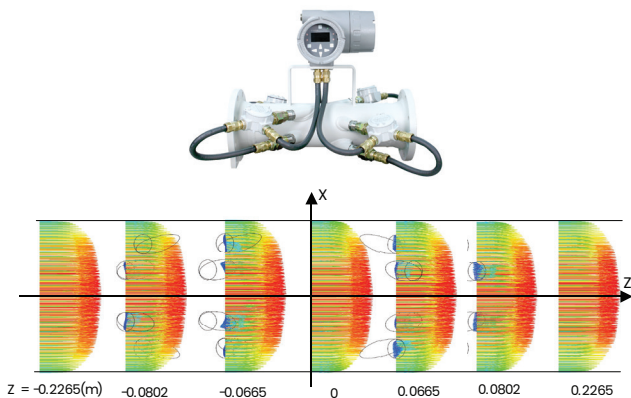

CFD simulation of acoustic port effects under highly turbulent flow

Limitations of tank level gauging

Measuring the volume of LNG in a tank is more than just measuring the level of the (boiling) LNG inside the tank. The temperature in the tank might not be constant, causing density variation. Corrections need to be made for tank expansion caused by the weight of the LNG inside. In case of level measurement on a ship, a pitch or even movement because of wave motion may require compensation. By making a direct volume measurement, Sentinel LNG overcomes all these additional sources of uncertainty.

Bundle waveguide technology™

The bundle waveguide technology acts as a buffer between the transducer and the flowing cryogenic liquid. These buffer assemblies use waveguide bundles to efficiently concentrate a greater amount of transducer ultrasonic signal into the process. At the same time, the bundles act as a buffer to protect the transducer from the cryogenic temperatures. The buffer is an all-metal construction with no moving parts. As a result, transducers can be safely removed from service without opening the pipeline. An insertion mechanism or expensive valves are not required.

Benefits

- Improved performance, reduced maintenance and dynamic flow measurement for cryogenic liquids
- Fully welded construction with no moving parts
- Ultrasonic transducers protected from cryogenic temperatures using Bundle Waveguide™ Technology
- Full bore design, zero pressure drop
- High accuracy to overcome limitations of tank level gauging
- Robust Path Configuration™ through extensive use of CFD (Computational Fluid Dynamics)

Applications

- Liquefied Natural Gas (LNG)
- Cryogenic fluid allocation
- Custody transfer
- Marine Cargo Verification

Dimensions and weights

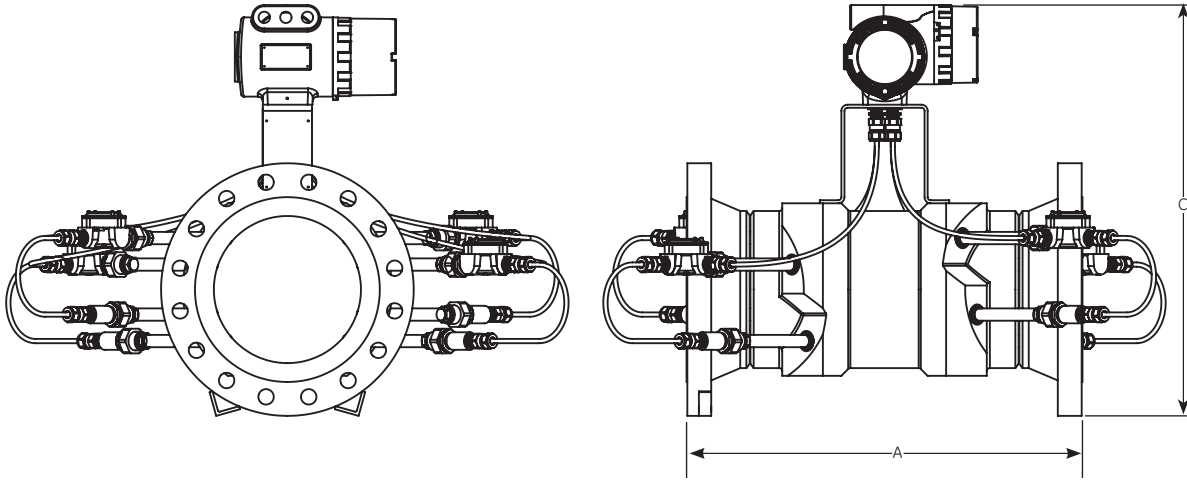

Weights are based on stainless steel.

Dimensions and weights in English units				
Diameter	Flange	A (in)	C (in)	Weight (lb)
4	150#	20	23.49	150
	300#	20	23.99	178
	600#	20	24.36	202
6	150#	22	25.76	211
	300#	24	26.51	268
	600#	26	27.26	341
8	150#	26	27.59	271
	300#	28	28.34	346
	600#	30	29.09	457
10	150#	28	29.84	371
	300#	30	30.59	492
	600#	32	31.84	746
12	150#	30	32.59	483
	300#	32	33.34	688
	600#	36	34.09	967
14	150#	36	34.09	798
	300#	38	35.09	1090
	600#	40	35.46	1352
16	150#	38	36.84	989
	300#	40	37.84	1361
	600#	42	38.59	1788
18	150#	38	37.84	1067
	300#	40	39.34	1542
	600#	44	39.96	2097
20	150#	46	41.25	1438
	300#	48	42.75	2141
	600#	50	43.50	2847
24	150#	48	44.59	2010
	300#	50	46.59	2976
	600#	52	47.09	3985

Dimensions and weights in metric units				
Diameter	Flange	A (mm)	C (mm)	Weight (kg)
4	150#	508	597	68
	300#	508	609	81
	600#	508	619	92
6	150#	559	654	96
	300#	610	673	121
	600#	660	692	155
8	150#	660	701	123
	300#	711	720	157
	600#	762	739	207
10	150#	711	758	168
	300#	762	777	223
	600#	813	809	339
12	150#	762	828	219
	300#	813	847	312
	600#	914	866	438
14	150#	914	866	362
	300#	965	891	494
	600#	1016	901	613
16	150#	965	936	463
	300#	1016	961	618
	600#	1067	980	811
18	150#	965	961	484
	300#	1016	999	700
	600#	1118	1015	951
20	150#	1168	1048	646
	300#	1219	1086	962
	600#	1270	1105	1280
24	150#	1219	1133	912
	300#	1270	1183	1350
	600#	1321	1196	1808

Technical Specifications

Performance

Fluid types	Liquid hydrocarbons
Flow measurement	Correlation transit time mode
Accuracy	< ± 0.25% of measured volume for flow rates between 2 and 30 ft/s (0.5 and 10 m/s).
Zero stability	< 0.007 ft/s (0.002 m/s)
Process temperature	-200° to +120°C (-328° to 248°F)
Ambient temperature	-40° to +60°C (-40° to 140°F)
Storage temperature	-40° to +80°C (-40° to +176°F)

Meter body

Path configuration	Four-path Robust Path Configuration™
Meter body materials	<ul style="list-style-type: none"> Stainless steel A182, Gr 304/304L Stainless steel A182, Gr 316/316L Others on request.
Pipe sizes	<ul style="list-style-type: none"> 4 in (100 mm) to 36 in (900 mm) Others on request.
Flange ratings	<ul style="list-style-type: none"> 150 # 300 # Others on request.
Pipe schedules	<ul style="list-style-type: none"> 10S 40S STD Others on request
PED compliance	PED Cat III, module H
Installation requirement	<p>Meter must be installed with 20D straight piping upstream and 5D straight piping downstream. Inlet and outlet piping ID must meet meter ID.</p> <p>Pressure, temperature and density connections must be located in the downstream piping. The 20D upstream piping must be free of any nozzles that could disturb the flow profile.</p>

Electronics

Electronics enclosure material	Four-path Robust Path Configuration™
Dimensions	<ul style="list-style-type: none"> Weight 25 lb (11.5 kg) Size (l x h x d): 13x11x9 in (33x27x23 cm)
Environmental protection	IP66
Power supply	<ul style="list-style-type: none"> 100 to 240 VAC 12 to 32 VDC
Power consumption	< 20 watt
Display	High contrast 128 x 64 pixel graphical display with LED illumination
Outputs	<ul style="list-style-type: none"> Two frequency/pulse outputs optically isolated from DC Two alarm relays One 4/20 mA output with HART
Inputs	Two 4/20 mA and one 100 ohm RTD input for density, pressure and temperature input (option). Three 4/20 mA inputs for density, pressure and temperature input (option).
Digital interfaces	<ul style="list-style-type: none"> HART over 4/20 mA output PanaLink over RS232/485/USB Modbus over RS232/485 (option)
Hazardous area certifications	<ul style="list-style-type: none"> USA/Canada: Class I, Div 1, groups B, C, & D Europe: ATEX II 2 G, Ex de IIC (Ex d IIC as option) IEC Ex: Ex de IIC (Ex d IIC as option)
CE compliance	<ul style="list-style-type: none"> 2004/108/EC EMC Directive 2006/95/EC LVD
Flow computer functionality	Integrated flow computer with full P and T volume corrections according to API 11.1

Flow ranges

Nominal diameter		0.5 m/s 1.69 ft/s	10 m/s 33 ft/s	0.5 m/s 1.69 ft/s	10 m/s 33 ft/s	0.5 m/s 1.69 ft/s	10 m/s 33 ft/s
in	mm	(m ³ /h)	(m ³ /h)	(GPM)	(GPM)	(BBL/h)	(BBL/h)
4	100	15	280	66	1230	94	1760
6	150	33	630	145	2770	207	3960
8	200	58	1130	255	4980	364	7120
10	250	91	1800	400	7900	873	11300
12	300	131	2500	580	11000	825	15700
14	350	179	3500	790	15400	1130	22000
16	400	233	4500	1030	19800	1470	28300
18	450	296	5700	1300	25100	1860	35900
16	500	365	7000	1600	30800	2300	44000
24	600	525	10000	2310	44000	3300	63000

Typical flow rates for 0.5 m (19.6 in) per second and 10 m (393 in) per second are listed above. The Sentinel LNG is a full bore meter and the flow range is a function of the pipe and not the meter itself.

Sentinel electronics SEN898 ordering information

SEN898 SEN 898 electronics for custody transfer measurement

Feature 1: Power

- 1 100 to 240 VAC operating voltage
- 2 12 to 32 VDC operating voltage

Feature 2: Inputs

- 0 None (not possible for LNG due to active temperature compensation)
- 1 One 100 ohm RTD input, Two 4-20mA inputs
- 2 Three 4-20mA inputs

Feature 3: Communications

- 0 None
- 1 Modbus RTU over RS232/RS485

Feature 4: Flow computer

- 0 None (not possible for LNG due to active temperature compensation)
- API API correction of volume per API Chapter 11.1 (for LCT only, 3 inputs required)
- LNG Active compensation for tube contraction (for LNG only, 3 inputs required)

Feature 5: Explosion proof

- 1 USA/CAN explosion proof, Class 1, Div 1, groups B, C, D
- 2 European flameproof, II 2G Ex d IIC
- 3 European flameproof increased safety, II 2G Ex de IIC

Feature 6: Electronics mounting

- L Local Mounting, if ordering with SEN-LCT or SEN-LNG
- R Remote Mounting, if ordering with SEN-LCT or SEN-LNG
- S Stand with remote mounting, cable length selectable (Max. 300 ft or 91 m)
- 0 None
- S Special

Sentinel LNG liquid custody transfer flow meter

SEN898 Sentinel Liquid Custody Transfer Flow Meter

Feature 1: Diameter

- 4 4" flowspool with RF flanges acc to ASME B16.5 (See Flow Rates table for metric conversion)
- 6 6" flowspool with RF flanges acc to ASME B16.5
- 8 8" flowspool with RF flanges acc to ASME B16.5
- 10 10" flowspool with RF flanges acc to ASME B16.5
- 12 12" flowspool with RF flanges acc to ASME B16.5
- 14 14" flowspool with RF flanges acc to ASME B16.5
- 16 16" flowspool with RF flanges acc to ASME B16.5
- 18 18" flowspool with RF flanges acc to ASME B16.5
- 20 20" flowspool with RF flanges acc to ASME B16.5
- 24 24" flowspool with RF flanges acc to ASME B16.5
- 28 28" flowspool with RF flanges acc to ASME B16.47
- 30 30" flowspool with RF flanges acc to ASME B16.47
- 32 32" flowspool with RF flanges acc to ASME B16.47
- 36 36" flowspool with RF flanges acc to ASME B16.47

Feature 2: Pressure class

- 150 150 lbs pressure rating
- 300 300 lbs pressure rating

Feature 3: Material

- 304 Stainless steel, A182 Grade 304/304L
- 316 Stainless steel, A182 Grade 316/316L

Feature 4: Schedule

- 10S Schedule size 10S
- 40S Schedule size 40S
- STD Schedule size STD
- S Special

Feature 5: Design criteria

- A ASME B31.3
- P ASME B31.3 with PED approval

Feature 6: Electronics mounting

- S Remote mounting, cable length selectable (max 300 ft or 91 m)

Feature 7: Material certs

- 0 None
- 1 Material certs
- 2 Material certs with EN 10204 3.1 inspection certificate

Feature 8: NACE requirements

- 0 None
- 1 NACE MR0175
- 2 NACE MR0103

Feature 9: Special requirements

- 0 None
- S Special

