

Sentinel LCT4

High accuracy ultrasonic flow meter

A true multi-viscosity meter

The LCT4 uses a number of proprietary algorithms to reduce viscosity effects, making it viscosity independent. No prover run or change of settings is required when viscosity changes. The meter retains its accuracy over the whole range between minimum and maximum viscosity, using only one calibration curve.

Peace of mind performance

The Sentinel LCT4 is a new addition to the Panametrics line of ultrasonic flow meters. Designed specifically for high accuracy measurement of crude oil, other liquid refined hydrocarbon products, and other non-hydrocarbon liquids, it delivers extremely reliable and repeatable results and meets the strict performance requirements of OIML R117-1 and API MPMS Chapter 5.8.

The LCT4 refines the high-reliability characteristics of its predecessor, the Sentinel LCT, into an aesthetically designed, compact meter body with integral cables, no extended buffers and no junction boxes. It continues to retain all of the advantages of ultrasonic flow measurement, including:

- No drifting or required periodic calibration
- No pressure drop
- No restriction in the pipe
- No moving parts and no filters or strainers

Calibration

Laboratory calibration on the LCT4 is performed to match the application, using either a single fluid or multiple fluids. Each meter is calibrated to adhere to the OIML R117-1 international standard. Other specific calibrations are available upon request.

There is no need for recalibration when replacing transducers or electronics. This has been independently tested by NMI as part of the OIML certification.

Advanced electronics

The Sentinel LCT4 electronics has digital signal processors that pack significant power in a simple package. As a standard package, several inputs and outputs are available, along with MODBUS and HART communication. The electronics is integrated with the flowcell body in a single unit, but can also be mounted remotely using an adapter and cable. Local programming and diagnostic access is done via magnetic induction to preserve hazardous area integrity. USB and RS232 connections are available to link with our Panaview software.



PanaView™ diagnostics

The PanaView software facilitates communication between the Sentinel LCT4 and a PC. Not only does this software provide real time flow data, but it is also capable of providing historical tracking of diagnostics and a full configuration audit trail. Pictured below is a view of our diagnostic master screen.

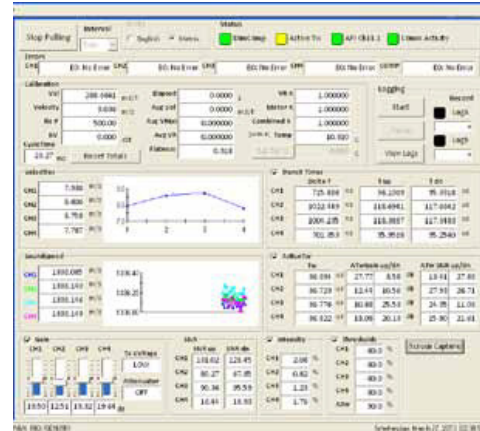

System weights

Vessel nominal diameter	Fully Assembled Dry Weight					
	English [lb]			Metric [kg]		
	150#	300#	600#	150#	300#	600#
3"	156	170	173	71	77	78
4"	180	200	224	82	91	102
6"	239	286	346	108	130	157
8"	334	398	497	151	181	225
10"	421	512	9694	191	232	315
12"	582	704	896	264	320	407
14"	746	925	1077	339	420	488
16"	978	1200	1469	444	545	666
24"	2112	2660	3202	958	1207	1453

Applications

- Liquid custody transfer measurement
- Allocation measurement
- Pipeline leak detection
- Crude oil and refined products
- Any critical liquid process

Flow ranges

Velocity						Volumetric ^{2,3}					
Nominal size		Vmin	Vmax	Vmin	Vmax	Qmin	Qmax	Qmin	Qmax	Qmin	Qmax
in.	mm	ft/s	ft/s	m/s	m/s	m3/h	m3/h	gal/m	gal/m	bbl/h	bbl/h
3	75	1	40	0.3	12.2	5	209	23	922	33	1317
6	6	1	40	0.3	12.2	9	360	40	1587	57	2268
6	150	1	40	0.3	12.2	20	818	90	3602	129	5147
8	200	1	40	0.3	12.2	35	1417	156	6237	223	8913
10	250	1	40	0.3	12.2	56	2233	246	9831	351	14049
12	300	1	40	0.3	12.2	80	3203	353	14100	504	20150
14	350	1	40	0.3	12.2	98	3905	430	17191	614	24566
16	400	1	40	0.3	12.2	129	5172	569	22772	814	32542
18	450	1	40	0.3	12.2	165	6618	728	29137	1041	41637
20	500	1	40	0.3	12.2	206	8241	907	36285	1296	51852
24	600	1	40	0.3	12.2	301	12022	1323	52932	1891	75639

- 1. Based on nominal sch 40S/STD inner diameter
- 2. These flowrates comprise product capability
- 3. OIML R117 applications will be limited based on ranges detailed in certificate

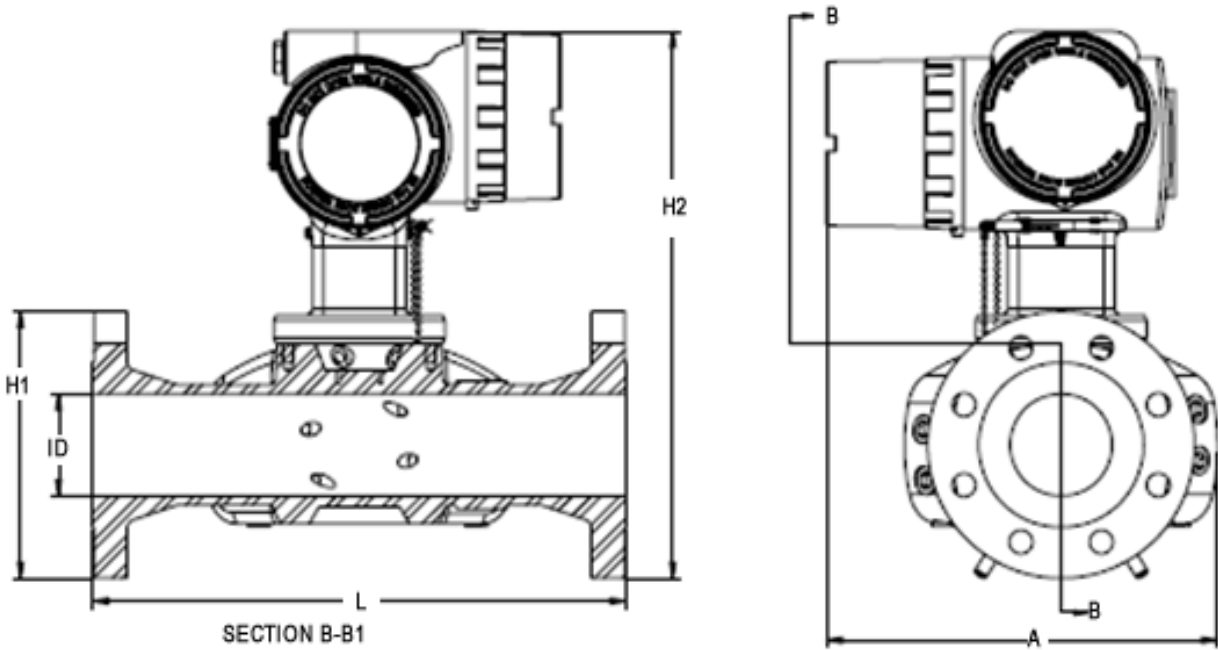

Flowcell Assembly for Sentinel LCT 4 with 3" and 4" Pipes

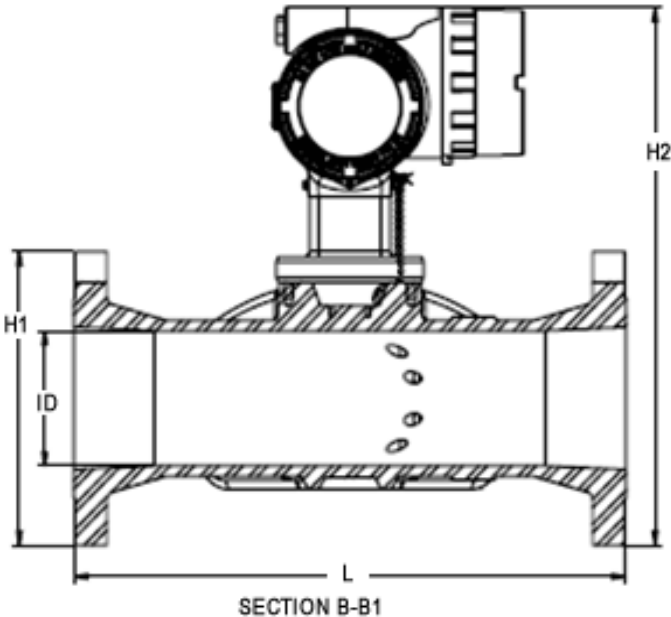

Flowcell Assembly for Sentinel LCT 4 with 3" and 4" Pipes

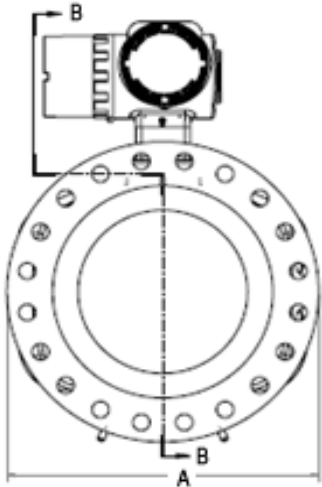
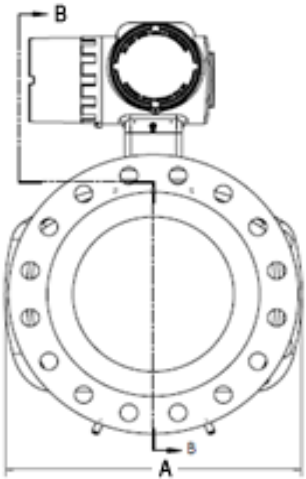
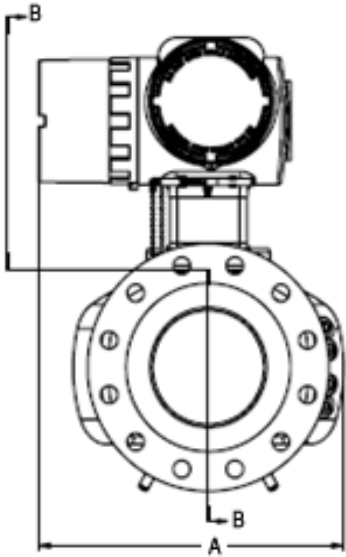

Technical Specifications

Flowcell dimensions

Diameter (inches)	Flange class	Dimensions in English units (rounded)			Dimensions in metric units (rounded)		
		L (in)	H2 (in)	A (in)	L (mm)	H2 (mm)	A (mm)
3	150#	20	19	13.82	508	480	351
	300#	20	20	13.82	508	490	351
	600#	20	20	13.82	508	490	351
4	150#	20	21	14.82	508	508	376
	300#	20	21	14.82	508	521	376
	600#	20	21	14.82	508	530	376
6	150#	22	23	15.97	559	563	406
	300#	24	23	15.97	610	582	406
	600#	26	24	15.97	660	601	406
8	150#	26	25	16.86	660	621	428
	300#	28	26	16.86	711	640	428
	600#	30	26	16.86	762	659	436
10	150#	28	27	19.14	711	675	486
	300#	30	28	19.14	762	694	486
	600#	32	29	20.00	813	726	508
12	150#	30	29	20.97	762	732	533
	300#	32	30	20.97	813	751	533
	600#	36	31	22.00	914	770	559
14	150#	36	32	23.39	914	792	567
	300#	38	33	23.00	965	818	584
	600#	40	33	23.75	1016	828	603
16	150#	38	35	23.88	965	882	605
	300#	40	36	25.50	1016	908	648
	600#	42	37	27.00	1067	927	686
18	150#	38	38	26.56	965	945	675
	300#	40	39	28.00	1016	983	711
	600#	44	41	29.25	1118	1037	743
20	150#	46	39	28.88	1168	983	734
	300#	48	41	30.50	1219	1021	775
	600#	50	43	32.00	1270	1078	813
24	150#	48	43	32.38	1219	1088	822
	300#	50	45	36.00	1270	1138	914
	600#	52	46	37.00	1321	1151	940

Operation and performance

Fluid types	Liquid hydrocarbons, crude and refined products, other liquids
Linearity	± 0.15% of measured volume for flow rates between 1 and 33 ft/s (0.3 and 10 m/s)
Uncertainty	± 0.027% according to API MPMS 5.8
Viscosity range	0 to 660 cSt
Reynolds range	> Re 10,000, consult factory for lower Reynolds numbers
Process temperature	Standard; -40 to +140°C (-40 to +248°F)
Ambient temperature	-40 to +60°C (-40 to 140°F)
Storage temperature	-40 to +85°C (-40 to +176°F)

Meter body

Meter body materials	<ul style="list-style-type: none">• Carbon steel SA216 Gr. WCB (Carbon steel)• Low temperature carbon steel SA352 Gr. LCB (Low temp carbon steel)• Stainless steel SA351 Gr. CF8 (304SS)• Stainless steel SA351 Gr CF8M (316SS)• Other materials available upon request
Pipe sizes	3 in. to 24 in.
Flange ratings	<ul style="list-style-type: none">• 150 #• 300 #• 600 #
Pipe schedules	<ul style="list-style-type: none">• S40/40S• 80/80S• 10S• STD• XS• Other schedules available upon request
PED compliance	PED Cat II, module B + C1 Installation requirement = min. 10D upstream with flow conditioner; 5D downstream

Electronics

Electronics enclosure material	<ul style="list-style-type: none">• Epoxy coated aluminium• Stainless steel A351, Gr 316/316L
Environmental protection	IP66
Power supply	<ul style="list-style-type: none">• 100 to 240 VAC• 12 to 32 VDC
Power consumption	7 W
Display	High-contrast 128 x 64 pixel LED graphical display
Outputs	<ul style="list-style-type: none">• Two isolated frequency/pulse outputs• Two alarm relays• One 4/20 mA output with HART®
Inputs	<ul style="list-style-type: none">• Two 4/20 mA and one 100 ohm RTD input for temperature, pressure and density input (option).• Three 4/20 mA inputs for temperature, pressure and density input (optional)
Digital interfaces	<ul style="list-style-type: none">• HART® over 4/20 mA output• PanaLink over RS232/485/USB• Modbus RTU over RS232/485
Flow computer functionality	Integrated flow computer with full P and T volume corrections according to API 11.1
Hazardous area certifications	<ul style="list-style-type: none">• USA/Canada: Class 1, Div 1, Groups B, C, & D• Europe: ATEX II 2 G Ex d IIB+H2 (Ex de as option)• IEC Ex: Ex d IIB+H2 (Ex de as option)
CE compliance	<ul style="list-style-type: none">• 2004/108/EC EMC Directive• 2006/95/EC LVD Directive
Custody transfer performance approvals	OIML R117-1 Accuracy Class 0.3; NMI Certificate TC7595 Multiple country-specific approvals available upon request.

Join the conversation and follow us on LinkedIn
[linkedin.com/company/panametricscompany](https://www.linkedin.com/company/panametricscompany)

Copyright 2025 by Panametrics LLC. All rights reserved.

PANA04IDS_R4 (12/2025)

 **Panametrics**

[panametrics.com](https://www.panametrics.com)