



DewPro[®] MMY30

Dew point transmitter

The DewPro MMY30 is a loop-powered transmitter with 4 to 20 mA output. The DewPro MMY30 is specifically designed to measure dew point or ppm in gases at line pressure or atmospheric pressure. The planar aluminum oxide sensor provides excellent corrosion resistance, longer calibration stability, quick response times, and an exceptionally low temperature coefficient. The optional integrated display with user interface provides full programming and diagnostic capability.

Technical Specifications

The DewPro MMY30 features an integral flow cell for filtration and flow regulation making it ideal for monitoring the moisture content in various process environments. Several options are available for the process connection allowing easy installation of the transmitter. Applications include desiccant air dryers, pipeline natural gas and industrial gases.

Features

- Loop-powered, 4 to 20 mA transmitter
- Fast response planar aluminum oxide sensor
- Integral filtering and flow regulation
- Trouble-free indoor or outdoor mounting
- Field validation with the MMY245 moisture analyzer
- Microcontroller electronics in Type 4X/IP67 enclosure

Options

- Integrated display with user interface
- FM approved intrinsically safe/explosion-proof, Class I,II,III, Division 1 and 2, Groups A,B,C,D,E,F&G hazardous (classified) locations
- English or metric fittings
- External display available with loop-powered supply and alarm contacts

Sensing element	Planar aluminum oxide sensor
Measurement range	-130°F to 50°F (-90°C to 10°C) dew point temperature; 0 to 10, 0 to 100, 0 to 1000 ppmv (fully adjustable with integral display)
Recommended recalibration cycle	12 months, depending on the application
Calibration accuracy	±3.6°F (±2°C) dew point at 77°F (25°C)
Maximum sensor relative humidity	50% at dew point temperature > 32°F (0°C)
Operating and storage temperature range	<ul style="list-style-type: none"> • Process: -40°F to 122°F (-40°C to 50°C) • Electronics: -40°F to 185°F (-40°C to 85°C)
Air bleed off at 100 psig (7 bar)	Approximately 1 SCFH (28 sl/h)
Maximum operating pressure	<ul style="list-style-type: none"> • 450 psig (31 bar, 3.1 MPa) • Inlet filter: 2 micron sintered stainless steel
Helium leak-rate	<10 ⁻⁶ mbar l/s
Output	4 to 20 mA loop-powered, 16 :A resolution
Flow block	316 stainless steel with 1/2 in MNPT or G 1/2 thread (DIN ISO 228)
Wrench width for flow block	1-5/8 in (42 mm)
Electronics	Microcontroller operated
Optional display	Four-digit numeric display with bar graph and matrix position indication. Four user interface keys for unit selections, output adjustments and ranging.
Power supply	24 VDC nominal, 12 to 30 VDC range
Protection	Type 4X/IP67
Weight	4.4 lb (2 kg)

European compliance Complies with EMC Directive 89/336/EEC and PED 97/23/EC for DN<25

- Optional certifications/ approvals**
- FM IS Class I,II,III, Division 1, Groups A,B,C,D,E,F&G, T5
 - FM XP-IS Class I, Division 1, Groups A,B,C&D, T5
 - FM NI Class I, Division 2, Groups A,B,C&D, T4A DIP Class II,III, Division 1, Groups E,F&G, T5
 - ATEX and IECEx
Ex db IIC T6 Gb
Ex tb IIIC T85°C Db
IP66

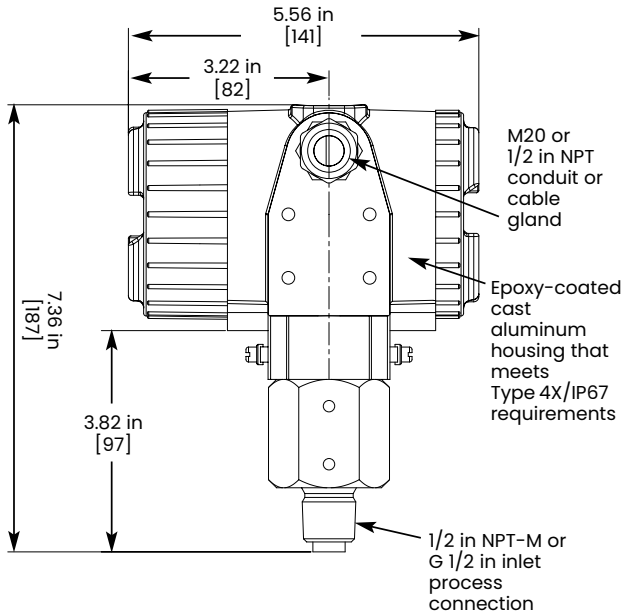

DewPro MMY30 with display option

Join the conversation and follow us on LinkedIn
[linkedin.com/company/panametricscompany](https://www.linkedin.com/company/panametricscompany)

Copyright 2024 by Panametrics LLC. All rights reserved.
 PANA063DS_R3 (08/2024)