



Optica™

The next generation humidity reference standard

Optica Series chilled mirror hygrometers offer National Institute of Standards and Technologies (NIST)—traceable humidity, temperature and pressure measurements for the connected generation. Now data is accessible from anywhere, any time, from within a browser over the Internet or from your Intranet.

Fundamental dew point measurement is a primary measurement used as a transfer standard for calibrating other humidity instruments and sensors. Chilled mirrors are also the sensors of choice when process and laboratory measurements call for high precision without long term drift. Optica may be used with four, fully interchangeable chilled mirror sensors to provide a measurement range from -103°F to 185°F (-75°C to 85°C) dew point with 0.36°F (0.2°C) or better accuracy. Inputs for a 100 W RTD and silicon-based piezoresistive pressure transducer ensure precision measurements, which are used to convert the dew point to any metric, English or user-defined unit of humidity measurement.

Communications

- Ethernet port
- Java-based applet loads in web browsers
- Data logger 6 megabyte memory
- Recorded data uploads in ASCII format
- Exports to spreadsheets
- Real time “strip chart” graphing
- Color VGA or 4 x 40 matrix display

Software

The Optica software is easy to navigate. Users select readout display, strip chart, analog output scale, digital communications, self-diagnostics, cleaning and data logging with intuitive pull-down menus. Setup values can be saved in memory and loaded anytime, either locally or from anywhere via the Ethernet port.

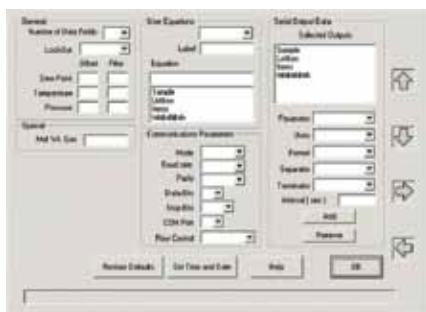

Functionality

The Optica simultaneously measures dew point, temperature and pressure. The analyzer is equipped with programmable math functions to produce custom units. In, exp +, -, x and / functions enable derived engineering units to be displayed, recorded and transmitted to data acquisition systems. The analyzer input channel is a standard 4 to 20 mA/0 to 5 VDC input, so the Optica can be connected to any type of process transmitter and be configured to display engineering units.



“Plug and play” setup is easily accomplished with standard connectors for power, sensor and analog outputs.

In the lab or on the plant floor

- Calibration labs
- Process control
- Clean rooms
- Environmental test chambers
- Precision HVAC monitoring and control
- Fuel cells
- Heat exchanger and refrigerant coil calorimeters
- Thermal processing/heat treating
- Semiconductor manufacturing
- Storage areas
- Pharmaceutical validation chambers
- Engine test cells and emissions testing
- Aircraft engines and turbines

Optica measures

- Temperature
- Relative humidity (% RH)
- Dew/frost point (Td)
- Absolute humidity (m/v)
- Mass mixing ratio (m/m)
- Volume mixing ratio (v/v)
- Wet bulb (Tw)
- Enthalpy (h)
- Water vapor pressure (e)
- Pressure
- Alarm relays
- Analog outputs

Chilled mirror sensors theory of operation

These chilled mirror hygrometers are used in standards and metrology labs as well as in industrial applications where precise and repeatable humidity measurement and control is required. The inherent accuracy and long term stability provides many advantages over other types of humidity measurement technologies. Chilled mirrors fundamentally measure the dew or frost point temperature directly by controlling a reflective surface to an equilibrium temperature between dew/frost formation and evaporation, and precisely measuring the temperature of the mirror at this point. The chilled mirror sensors consist of a small polished hexagonal rhodium, or platinum mirror attached to thermoelectric cooling module (TEC). The Optica analyzer's servo controller applies current to the TEC, which causes the mirror to cool. The mirror is illuminated with a regulated Gas emitter, which transmits light in the infrared spectrum. The light reflected by the mirror is received by a photodetector. When water vapor condenses on the mirror as water or frost (ice crystals), the light received by the photodetector is reduced due to scattering. This results in the servo controller reducing the power causing the mirror to slightly warm. The Optica's control system will modulate the amount of current flowing through the TEC to maintain a temperature where the rate of condensation and evaporation of water molecules and the mass of water on the mirror is constant. The resulting temperature of the mirror is then, fundamentally by definition, equal to the dew or frost point temperature. A precision four-wire platinum RTD imbedded in the mirror measures the temperature. The accuracy of the dew point measurement has been validated to an accuracy of $\pm 0.36^\circ\text{F}$ ($\pm 0.2^\circ\text{C}$) dew/frost point. The precision can also be enhanced to $\pm 0.27^\circ\text{F}$ ($\pm 0.15^\circ\text{C}$) dew/frost point. Dry bulb temperature is measured with a precise four-wire 100 W platinum RTD and pressure is measured with a piezoresistive silicon pressure transducer. The dew/frost point and dry bulb RTD resistance signals are conditioned and amplified by the Optica monitor to display and transmit dew/frost point and temperature. The pressure sensor transmits an amplified 4 to 20 mA signal that is powered by the Optica. The cardinal measurements of dew/frost point, dry bulb temperature and pressure are used to calculate other humidity parameters such as relative humidity, wet bulb, mass mixing ratio, volumetric mixing ratio, absolute humidity, enthalpy and water vapor pressure values using psychometric equations.

The RTD sensor is embedded in the chilled mirror and never comes in contact with the process or test environment. The wetted parts consist of the platinum or rhodium mirror, a stainless steel or mylar vapor barrier and epoxy sealant. The net result is drift-free humidity measurement designed to maintain accuracy specifications for many years. Chilled mirrors require a nominal flow rate across the mirror to achieve the optimal dew/frost formation and response time. The sensor should either be installed in a duct with moving air or be equipped with a sampling pump. The optimum flow rate is 0.5 to 5 SCFH (0.25 to 2.5 L/min). Our application engineers will discuss your application in detail and provide a recommendation for a complete measurement system best suited to your needs.

Self cleaning and digital control

For environments where physical contaminants such as dust, oil mist and pollen are present, the use of a sampling system with a filter media is recommended. The filter media must be hydrophobic so as to not absorb or release water vapor into the test stream. Over time the mirror can be etched or pitted by particulate, altering the light scattering characteristics. Panametrics mirrors are field replaceable. The standard rhodium mirror may be upgraded to platinum for industrial applications.

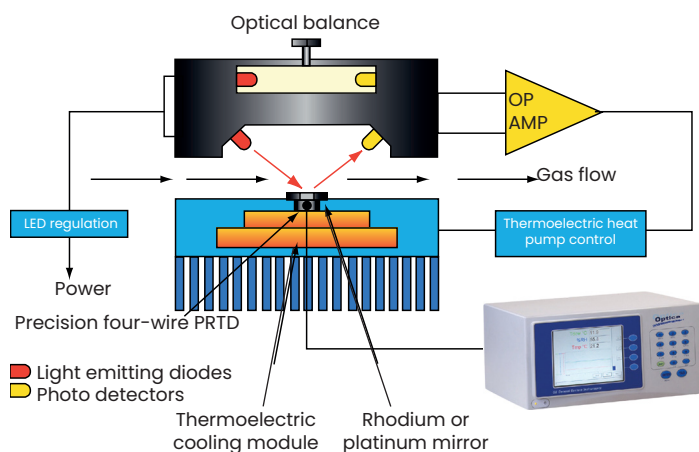

PACER® (Program Automatic Error Reduction) is a patented contamination compensation scheme. The PACER cycle can be initiated manually or by programming a timed cycle. The cycle starts by capturing the data (during the PACER cycle a constant value is transmitted) and cooling the mirror well below the dew point such that a thick dew layer forms on the mirror. The mirror is then rapidly heated. During the heating a significant amount of soluble and some non-soluble contamination is flash evaporated. The contamination left on the mirror tends to aggregate in dry islands or spots (much like a glass that comes out of a dishwasher). This process leaves approximately 85% of the mirror clean. The light signal received by the photodetector is compared against a reference LED/photodetector and the two signals are "balanced," effectively negating the effect of the residual contamination left on the mirror. The PACER cycle works very well, but eventually manual cleaning may be required. All the chilled mirror sensor surfaces are accessible for manual cleaning. Cleaning is a simple process consisting of wiping the mirror with a cotton swab wetted with cleaning solution or distilled water. (Distilled water is recommended as the final cleaning agent.)

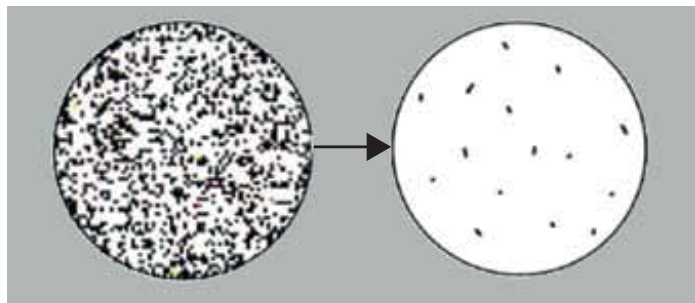

Before PACER cycle

After PACER cycle

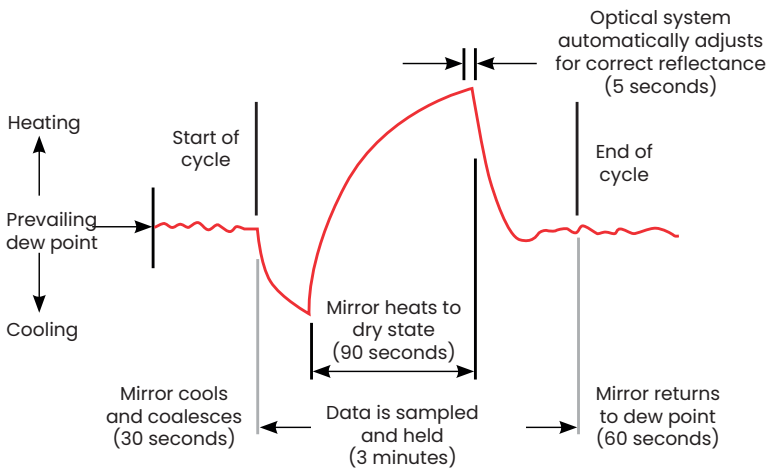

Typical PACER cycle

Digiloop™ control overcomes the limitations of traditional analog PID (Proportional Integral and Derivative) control. Analog temperature control produces oscillations particularly at high or trace humidity levels. It is difficult to apply self-tuning or PID constants to analog control loops, which are over damped or under damped. Digiloop utilizes digital sampling and feed-forward control by taking time-based samples when the dew point is within a predetermined proportional band. By recording the oscillations, the digital control effectively predicts the magnitude of change and adjusts the current to the thermoelectric cooling module, which steps the mirror temperature in 0.09°F (0.05°C) increments. This results in a significantly improved control and dew point precision.

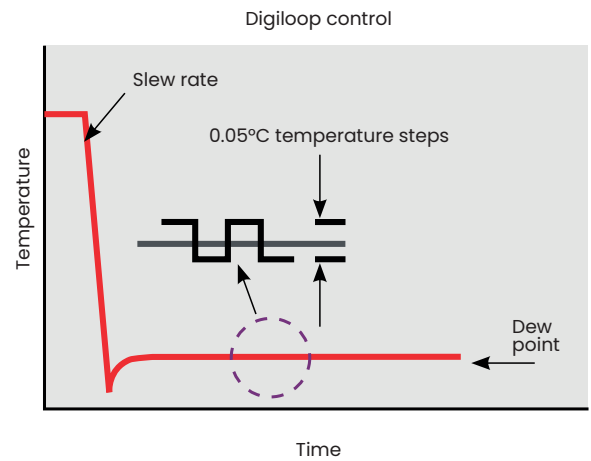
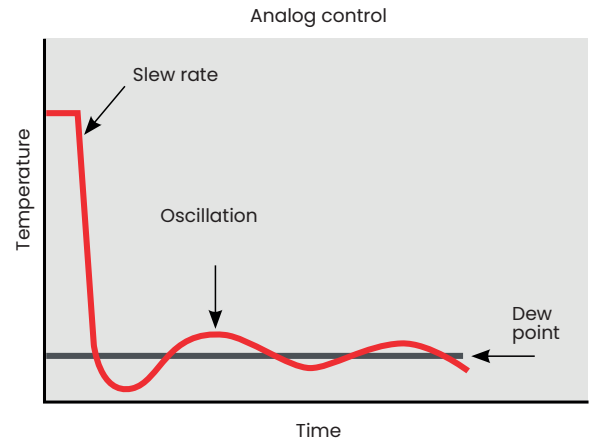

Technical Specifications

Optica

Color VGA with data logger and ethernet communications available in bench or 19" rack styles

Power	95 to 265 VAC, 50/60 Hz, 200 watts
Electrical I/O	IEC-style AC receptacle (bench mount), multipin chilled mirror and temperature sensor/cable connectors, screw terminals for analog outputs, DB-9 for RS232 and 10 base-T for ethernet.
Measured Parameters	Dew point, temperature and 4 to 20 mA/0 to 5 VDC
Calculated Parameters	Relative humidity, wet bulb, mass mixing ratio, volumetric mixing ratio, absolute humidity, water vapor pressure and enthalpy in English and metric units, as well as user-configured units.
Inputs	1/3 Class A DIN 43760, 100 W RTD and dew/frost point and dry bulb temperature. Loop powered 4 to 20 mA DC at 500 W maximum load.
Accuracy	System accuracy $\pm 0.36^\circ\text{F}$ ($\pm 0.2^\circ\text{C}$) for dew/frost point, $\pm 0.27^\circ\text{F}$ ($\pm 0.15^\circ\text{C}$) for temperature, 0.5% full scale (FS) for pressure.
Range	Governed by sensor
Hysteresis	Negligible
Sensitivity	0.1% FS
A/D	16 bit
Data logger memory	6 megabytes
Display	1/4 color VGA enables up to six parameters to be displayed

Operating temperature	32°F to 122°F (0°C to 50°C)	
Cooling rate	0.27°F (1.5°C)/sec typical above 32°F (0°C)	
Digital Interface	RS232 port, ethernet port*	
Digital output format	Data ASCII text, ethernet java applet password protected*	
TCP/IP address	User programmable*	
Analog outputs	(2) 4 to 20 mA and 0 to 5 VDC, user configurable and scalable	
Analog outputs	(2) 5 A at 250 V, form C, (SPDT) relays	
Enclosure	Benchtop:	Type 1
Weight	Benchtop:	8 lb (3.6 kg)

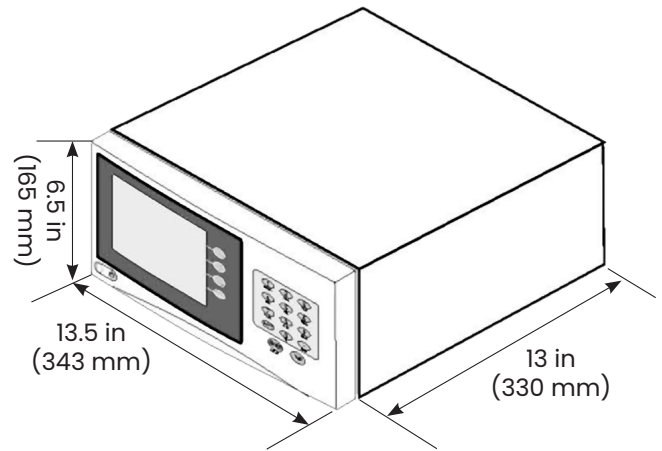

1111H single-stage chilled mirror specifications

Sensing element	Four-wire 1/3 Class A DIN 43760 RPT, 100 W @ 32°F (0°C)	
Dew/frost point accuracy	Standard:	±0.36°F (±0.2°C)
	Optional:	±0.27°F (±0.15°C)
Sensitivity	>0.05°F (>0.03°C)	
Repeatability	±0.09°F (±0.05°C)	
Hysteresis	Negligible	
Cooling stages	Single stage thermoelectric cooling (TEC) module	
Auxiliary cooling	Not applicable	
Depression	81°F (45°C) at 77°F (25°C) dry bulb and atmospheric pressure	
Typical measurement range	5°F to 77°F (-15°C to 25°C) dew/frost point (Td) in air @ 77°F (25°C) and atmospheric pressure. Equivalent to 5% to 100% RH. Other humidity parameters based on calculations.	
Sample flow	0.5 to 5.0 SCFH (0.25 to 2.5 L/min)	
Operating temperature	5°F to 176°F (-15°C to 80°C)	
Pressure	-3 to 200 psig (0.8 to 15 bar)	
Power	Derived from Optica	
Sensor body	Epoxy-coated aluminum	
Filter	Polytetrafluoroethylene (PTFE) filter (standard on 1111H-GE)	
Mirror	Standard:	Rhodium-plated copper
	Optional:	Solid platinum

Sensor wetted material	Aluminum, copper, mylar, PTFE, rhodium or platinum
Vapor barrier	Mylar
Electrical connector	MS-style multipin connector
Weight	1 lb (1.4 kg) net

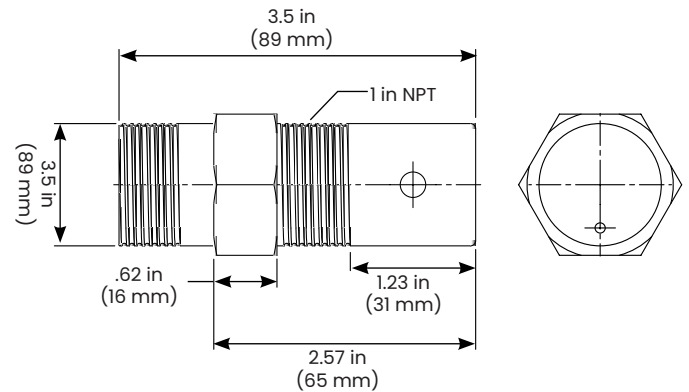

Accessories

MB-II	Wall mounting bracket
PTFE-GE	PTFE filter
P	Platinum mirror
X	Enhanced accuracy ±0.27°F (±0.15°C) Td
O111D	Pressure boss (1111H only)

D2 two-stage chilled mirror specifications

Sensing element	Four-wire 1/3 Class A DIN 43760 RPT, 100 W @ 32°F (0°C)	
Dew/frost point accuracy	Standard:	±0.36°F (±0.2°C)
	Optional:	±0.27°F (±0.15°C)
Sensitivity	>0.05°F (>0.03°C)	
Repeatability	±0.09°F (±0.05°C)	
Hysteresis	Negligible	
Cooling stages	Two-stage TEC module	
Auxiliary cooling	Not applicable	
Depression	117°F (65°C) at 77°F (25°C) and atmospheric pressure	
Typical measurement range	31°F to 77°F (-35°C to 25°C) dew/frost point (Td) in air @ 77°F (25°C) and atmospheric pressure. Equivalent to 0.7% to 100% RH. Other parameters based on calculations.	
Sample flow	0.5 to 5.0 SCFH (0.25 to 2.5 L/min)	
Operating temperature	-13°F to 185°F (-25°C to 85°C)	
Pressure	150 psig (11 bar) maximum	
Power	Derived from Optica monitor	
Sensor body	Cast aluminum with 314 stainless steel flow cell	
Mirror	Standard:	Rhodium-plated copper
	Optional:	Solid platinum
Sensor wetted material	302, 316 stainless steel, silicone o-ring, BK-7 glass, rhodium or platinum mirror	
Vapor barrier	Stainless steel	

Inlet/outlet	1/4 in OD tubing compression fittings
Electrical connector	Sub-D 15-pin connector mates with 2130 cable
Weight	4 lb (1.8 kg) net

Ø .107 in (4.75 mm) through 4 places

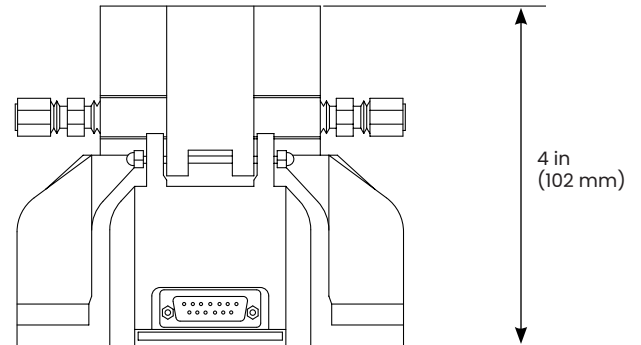
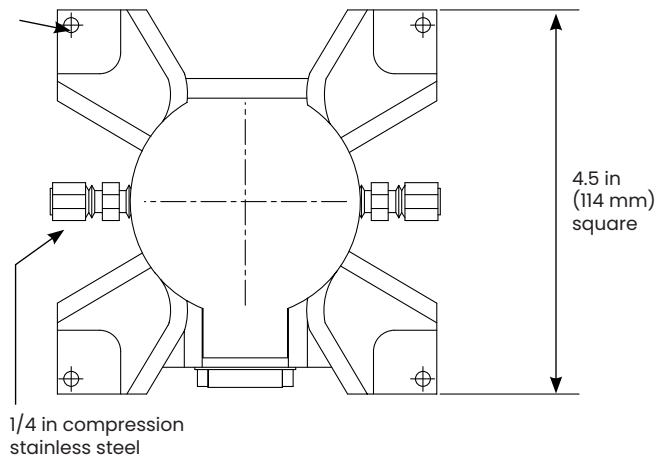

Accessories

- P Platinum mirror
- X Enhanced accuracy ±0.27°F (±0.15°C) Td

1211H two-stage chilled mirror specifications

Sensing element	Four-wire 1/3 Class A DIN 43760 RPT, 100 W @ 32°F (0°C)	
Dew/frost point accuracy	Standard:	±0.36°F (±0.2°C)
	Optional:	±0.27°F (±0.15°C)
Sensitivity	0.05°F (>0.03°C)	
Repeatability	±0.09°F (±0.05°C)	
Hysteresis	Negligible	
Cooling stages	Two-stage TEC module	
Depression	117°F (65°C) at 77°F (25°C) and atmospheric pressure	
Typical measurement range	31°F to 77°F (-35°C to 25°C) dew/frost point (Td) in air @ 77°F (25°C) and atmospheric pressure. Equivalent to 0.7% to 100% RH. Other parameters based on calculations.	
Sample flow	0.5 to 5.0 SCFH (0.25 to 2.5 L/min)	
Operating temperature	5°F to 212°F (-15°C to 100°C)	
Pressure	300 psig (21 bar) maximum	
Power	Derived from Optica	
Sensor body	Cast aluminum with 314 stainless steel flow cell	
Mirror	Standard:	Rhodium-plated copper
	Optional:	Solid platinum
Sensor wetted material	302, 316 stainless steel, silicone o-ring, BK-7 glass, rhodium or platinum mirror	
Vapor barrier	Mylar (upgradeable to stainless steel)	
Inlet/outlet	1/4 in OD tubing compression fittings	

Electrical connector MS-style multipin connector mates with 2120 cable

Weight 4 lb (1.8 kg) net

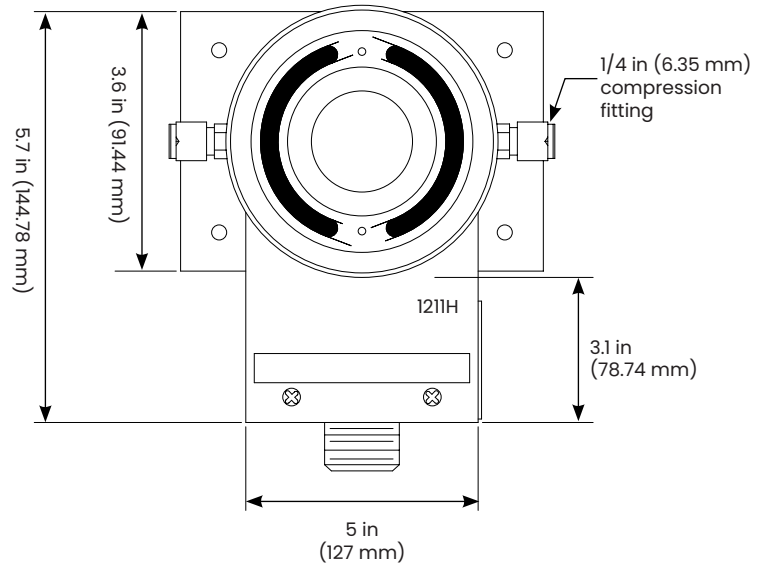

Accessories

- P** Platinum mirror
- X** Enhanced accuracy ±0.27°F (±0.15°C) Td
- S** Stainless steel vapor barrier

SIM-12 heated two-stage chilled mirror specifications

Sensing element	Four-wire 1/3 Class A DIN 43760 RPT, 100 W @ 32°F (0°C)
Dew/frost point accuracy	Standard: ±0.36°F (±0.2°C) Optional: ±0.27°F (±0.15°C)
Sensitivity	>0.05°F (>0.03°C)
Repeatability	±0.09°F (±0.05°C)
Hysteresis	Negligible
Cooling stages	Two-stage TEC module
Auxiliary cooling	Not applicable
Depression	153°F (85°C) at 167°F (75°C) body temperature and atmospheric pressure
Typical measurement range	14°F to 167°F (-10°C to 75°C) dew/frost point (Td) in air @ 167°F (75°C) body temperature in 77°F (25°C) ambient temperature and atmospheric pressure. Equivalent to 0.7% to 100% RH. Other parameters based on calculations.
Sample flow	0.5 to 5.0 SCFH (0.25 to 2.5 L/min)
Operating temperature	5°F to 212°F (-15°C to 100°C)
Heater control	Thermostatically controlled. Set point of 77°F (25°C), 104°F (40°C), 131°F (55°C), 158°F (70°C), 185°F (85°C) and 212°F (100°C)
Pressure	50 psig (4.5 bar) maximum 100/115/230 VAC, 50/60 Hz, 75 watts
Sensor body	Cast aluminum with 314 stainless steel flow cell
Sensor wetted material	302, 316 stainless steel, silicone o-ring, BK-7 glass, rhodium or platinum mirror

Mirror	Standard: Rhodium plated copper Optional: Solid platinum
Vapor barrier	Mylar (upgradeable to stainless steel)
Electrical connector	MS-style multipin connector IEC receptacle for AC power
Weight	7 lb (3.2 kg) net

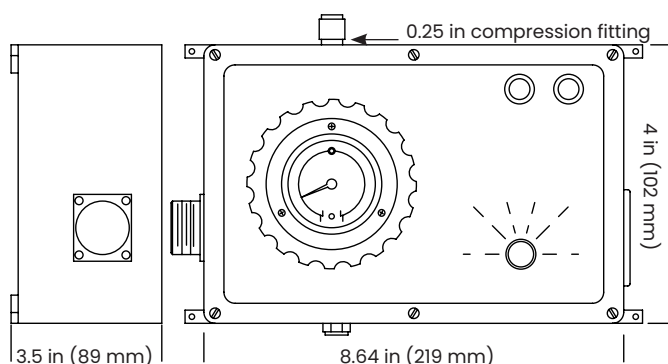

Accessories

P	Platinum mirror
X	Enhanced accuracy ±0.27°F (±0.15°C) Td
S	Stainless steel vapor barrier
HSS-12	Heated sampling system. SIM-12 heated chilled mirror, SIM-HFT heated filter module and SIM-HFM heated flowmeter mounted on a plate with SIM-HSL heated sample line.

1311-DR four-stage chilled mirror specifications

Sensing element	Four-wire 1/3 Class A DIN 43760 RPT, 100 W @ 32°F (0°C)	
Dew/frost point accuracy	Standard:	±0.36°F (±0.2°C)
	Optional:	±0.27°F (±0.15°C)
Sensitivity	>0.05°F (>0.03°C)	
Repeatability	±0.09°F (±0.05°C)	
Hysteresis	Negligible	
Cooling stages	Four-stage TEC module	
Auxiliary cooling	Liquid cooling jacket	
Depression, air cooled	171°F (95°C) at 77°F (25°C) and atmospheric pressure	
Depression, liquid cooled	189°F (105°C) with 59°F (15°C) cooling water	
Typical measurement range	<ul style="list-style-type: none"> -85°F to 77°F (-65°C to 25°C) dew/frost point (Td) in air @ 77°F (25°C) and atmospheric pressure. -103°F to 59°F (-75°C to 15°C) in liquid-cooled mode with 59°F (15°C) coolant. Other parameters based on calculations. 	
Sample flow	0.5 to 5.0 SCFH (0.25 to 2.5 L/min)	
Operating temperature	32°F to 95°F (0°C to 35°C)	
Pressure	300 psig (22 bar) maximum	
Power	100/115/230 VAC, 50/60 Hz, 300 watts	
Sensor body	Cast aluminum with 314 stainless steel flow cell	
Mirror	Standard:	Rhodium-plated copper
	Optional:	Solid platinum

Sensor wetted material	302, 316 stainless steel, silicone o-ring, BK-7 glass, rhodium or platinum mirror
Vapor barrier	Mylar (upgradeable to stainless steel)
Inlet/outlet	1/4 in (6 mm) OD tubing compression fittings
Electrical connector	MS-style multipin connector mates IEC receptacle for AC power
Weight	34 lb (16 kg) net

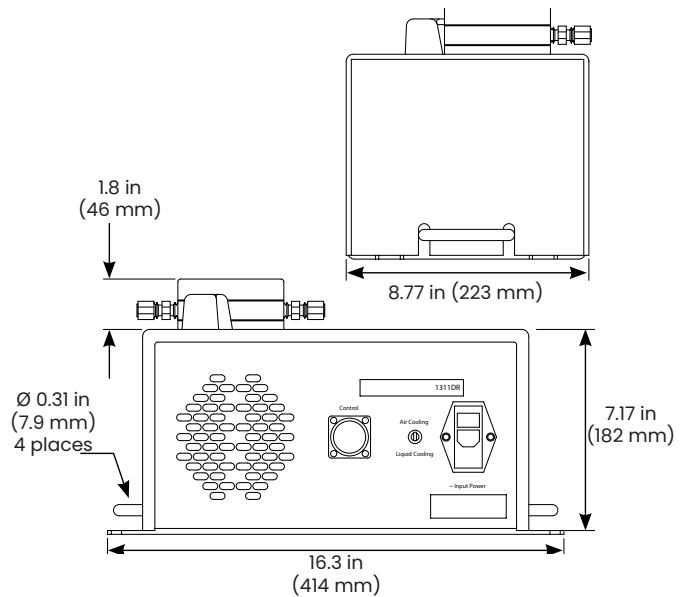

Accessories

- P** Platinum mirror
- X** Enhanced accuracy ±0.27°F (±0.15°C) Td
- S** Stainless steel vapor barrier

T-100 four-wire PRTD temperature sensor specifications

Sensing element	Four-wire 1/3 Class A DIN 43760 RPT, 100 W @32°F (0°C)
Accuracy	System at 25°C Standard: ±0.27°F (±0.15°C) Optional: ±0.18°F (±0.1°C)
Measurement range	-148°F to 212°F (-100°C to 100°C)
Response time	7 seconds for 77°F to 158°F (25°C to 70°C) step change in fluid
Sensor body	Stainless steel sheath
Cable	PTFE insulation rated to 302°F (150°C). 10 ft (3 m) standard length.

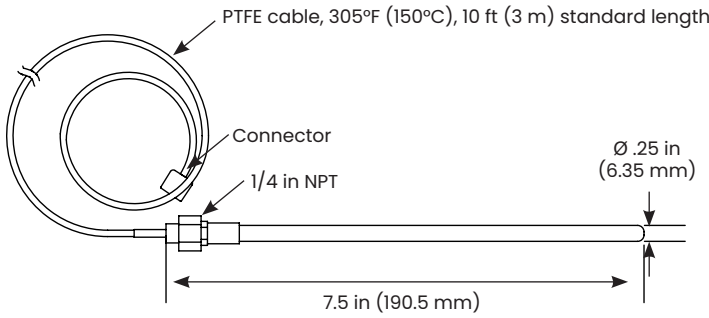

Fittings	Adjustable 1/4 in NPT stainless steel compression fitting
Strain relief	Stainless steel spring
Power	Low voltage derived from Optica
Weight	2 lb (0.9 kg) net
Options	Additional cable length

PT series pressure transducer specifications

Sensing element	Micro-machined silicon strain gauge
Accuracy	System at 77°F (25°C), ±0.5% of full scale
Range PT-30A	0 to 30 psia (0 to 2 bar)
Range PT-300A	0 to 300 psia (0 to 21 bar)
Response time	1 second for 90% of steady state (10% to 90% change)
Operating ranges	<ul style="list-style-type: none"> -4°F to 176°F (-20°C to 80°C) ambient temperature -13°F to 248°F (-25°C to 120°C) process temperature
Temperature effect	<1% FS on accuracy from 14°F to 122°F (-10°C to 50°C) for pressure 6 psi (0.4 bar)
Power	9 to 30 VDC. Derived from Optica monitor

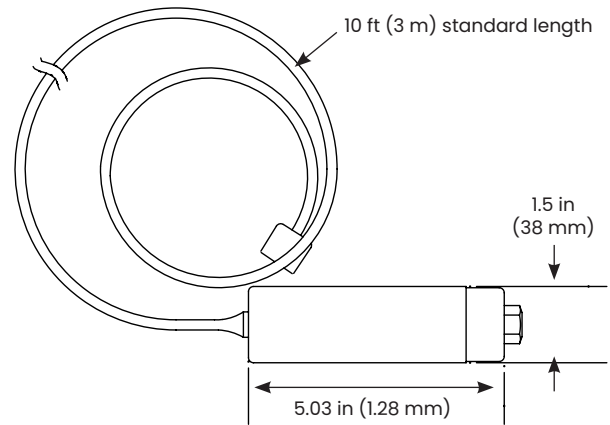

Sensor body material	316 stainless steel
Sensor wetted material	316 stainless steel and Hastelloy diaphragm
Cable	PVC insulation. 10 ft (3 m) standard length process connection 1/4 in F-NPT
Weight	4 lb (1.8 kg) net

Chilled mirror sensor depression

1111H Single-Stage Chilled Mirror

45°C depression

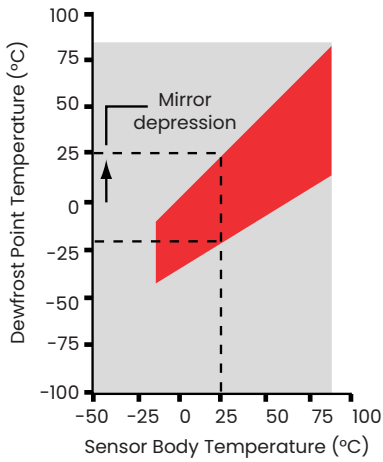

1211H two-stage chilled mirror sensor body temperature °C

65°C depression

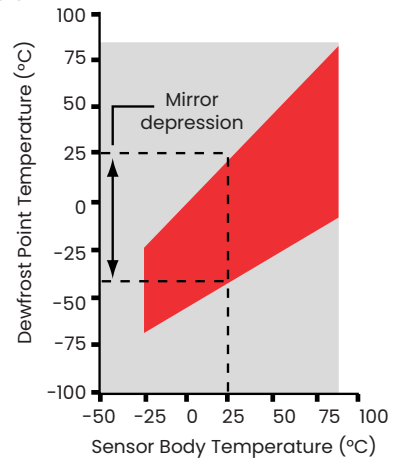

D2 two-stage chilled mirror sensor body temperature °C

65°C depression

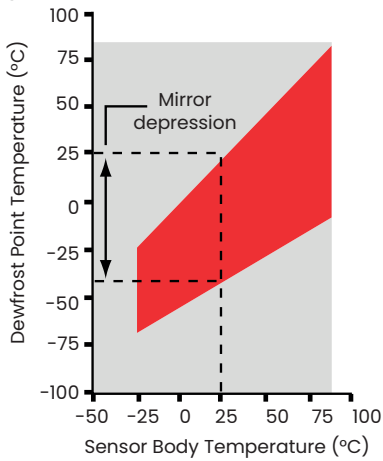

SIM-12 heated two-stage chilled mirror sensor body temperature °C

65°C depression

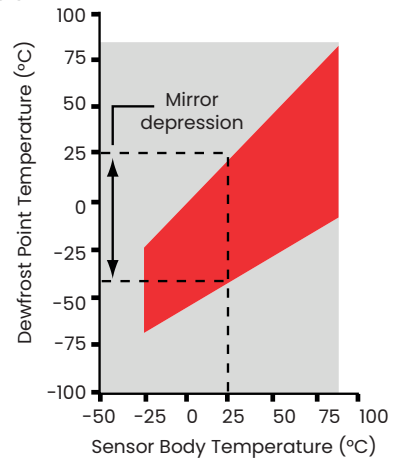

1311-DR four-stage chilled mirror sensor body temperature °C

95°C depression

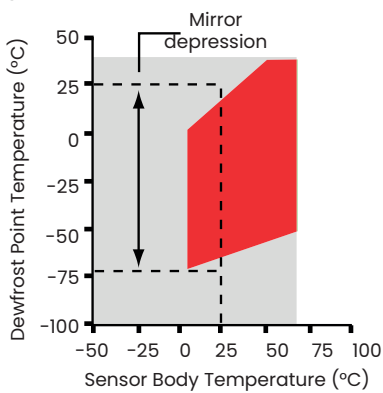

Accessories

Optica SSM sampling system specifications

Enclosure	Polycarbonate
Fittings	Brass 1/4 in OD tubing
Compression internal tubing	Impolene
Rotameter	0.5 to 5 SCFH (0.2 to 2 L/min)
Maximum vacuum	-98 in (-250 mm) of Hg
Free air displacement	14 SCFH (6.5 L/min)
Maximum temperature	100°F (38°C)
Power	95 to 265 VAC, 50/60 Hz, 15 watts

FM-1 rotameter/needle valve

Materials	Clear acrylic body, buna-N seals, black glass float, brass valves
Fittings	1/4 in compression
Range	0.5 to 5 SCFH (0.2 to 2 L/min)
Pressure	100 psig (6 bar) maximum
Temperature	150°F (65°C) maximum

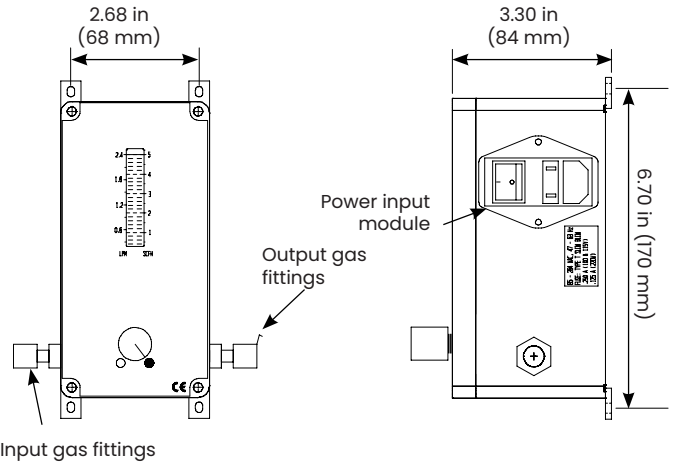

BF-10DX general purpose filter

Recommended for dew points $\geq 32^\circ\text{F}$ ($\geq 0^\circ\text{C}$)

Materials	Anodized aluminum head, nylon bowl, nylon internals, Buna-N Seals
Fittings	1/4 in compression
Temperature	-150°F to 220°F (-101°C to 104°C)
Filter	Borosilicate glass
Porosity	93% of particles over 0.1 μm
Pressure	150 psig (10 bar) maximum
BF-12SS	Box of 10 replacement filter elements

Accessories

BF-12SS stainless steel filter

Recommended for dew points $\leq 32^{\circ}\text{F}$ ($\leq 0^{\circ}\text{C}$)

Materials 316 stainless steel head, bowl and internals.
Viton seals

Fittings 1/4 in (6 mm) compression

Temperature -150°F to 220°F (-101°C to 104°C)

Filter Borosilicate glass

Porosity 93% of particles over $0.1\ \mu\text{m}$

Pressure 340 bar (5000 psig) maximum

BF-12SS Box of ten replacement filter elements

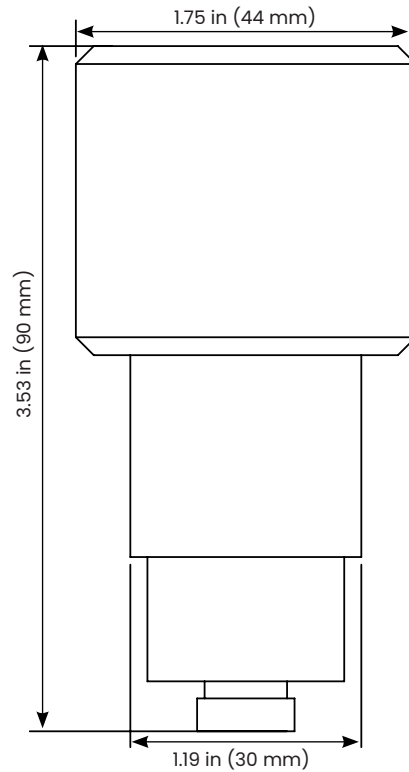
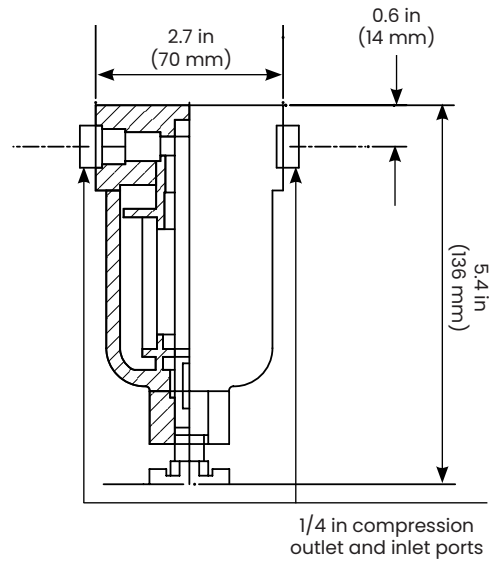

Ordering code guide



Optica Monitor

Color VGA Display With Logger/Ethernet

- A** Benchtop
- B** Benchtop with rack mount bracket

Optica Channel One

- 1** Unit to be sold with new chilled mirror (see sensor section)
- 2** Use the existing D2 (conversion cable 2160 required)
- 3** Use with existing 1111H, 1211H, SIM-12H and 1311DR (conversion cable 2160 required)
- 4** Use with existing 1311XR (conversion cable 2140 required) 1 Unit to be sold with new chilled mirror (see sensor section)

Default Code

- 0** Default code

Chilled Mirror Cable

Cable Type

- 0** No cable required
- C** Adapter cable for existing sensor/cable installation 2 ft (.61 m)
- A** 10 ft (3 m) standard length
- X** Specify length in ft (m)

Chilled Mirror Sensor

Sensor

- 0** No sensor
- A** 1111H
- B** 1111H-GE
- C** D2
- D** 1211H

SIM-12

- E** 100 VAC
- F** 115 VAC
- G** 230 VAC

HSS-12

- H** 100 VAC
- J** 115 VAC
- K** 230 VAC

1311DR

- L** 100 VAC
- M** 115 VAC
- N** 230 VAC

Accuracy and mirror

- 1** S/R/M standard accuracy, rhodium mirror, mylar vapor barrier
- 2** S/P/M standard accuracy, platinum mirror, mylar vapor barrier
- 3** S/P/P standard accuracy, platinum mirror, stainless steel vapor barrier
- 4** X/R/M enhanced accuracy, rhodium mirror, mylar vapor barrier
- 5** X/P/M enhanced accuracy, platinum mirror, mylar vapor barrier
- 6** X/P/P enhanced accuracy, platinum mirror, stainless steel vapor barrier
- 7** S/R/P standard accuracy, rhodium mirror, stainless steel vapor barrier (D2)
- 8** X/R/P enhanced accuracy, rhodium mirror, stainless steel vapor barrier (D2)
- 9** S/P/P standard accuracy, platinum mirror, stainless steel vapor barrier (D2)

Temperature Sensor

Sensor

- 0** No temperature sensor
- A** T-100 with 10 ft (3 m) cable (standard accuracy)
- B** T-100 with 10 ft (3 m) cable (enhanced accuracy)
- X** T-100 with build to fit cable (standard accuracy)
- Z** T-100 with 10 ft (3 m) cable (enhanced accuracy)

Pressure sensors

- 0** No pressure sensor
- A** PT-30A 10 ft (3 m) cable (standard)
- B** PT-30A build-to-fit cable
- X** PT-300A 10 ft (3 m) cable (standard)
- Z** PT-300A build-to-fit cable

Join the conversation and follow us on LinkedIn
[linkedin.com/company/panametricscompany](https://www.linkedin.com/company/panametricscompany)

Copyright 2023 by Panametrics LLC. All rights reserved.
PANA068DS_R8 (04/2023)



AddValue Instruments BV
Hoevelakenweg 185-bis
3784 WH Terschuur (Barneveld)
The Netherlands
E: info@addvalueinstruments.com
T: +31 (0)342 224015



[panametrics.com](https://www.panametrics.com)