



OptiSonde™

Chilled mirror hygrometer

Chilled mirror hygrometers are used in standards and metrology labs as well as in industrial applications where precise and repeatable humidity measurement and control are required. The inherent accuracy and long term stability provide many advantages over other types of humidity measurement technologies.

PANA069DS Rev. 4

The OptiSonde chilled mirror hygrometer is a National Institute of Standards and Technology (NIST) traceable humidity transfer standard at an exceptional value. The compact rugged analyzer is connected to either a single- or two-stage chilled mirror sensor and PRTD. Chilled mirrors are the humidity sensors of choice when laboratory and process measurements require high precision without long-term drift. An LCD indicates two simultaneous user-configured parameters. OptiSonde provides two user-configured analog (4 to 20 mA) outputs. The display and front panel keys enable quick and easy configuration.

The OptiSonde easily records humidity and temperature data from a wide variety of applications. The analyzer is equipped with a data logger capable of recording for 100 days at a sample rate of 1 second and is equipped with an internal real-time clock. The saved data is uploaded to a PC using terminal software as ASCII delimited text, enabling it to be opened by Excel® and other spreadsheet programs for data reduction, graphing and statistical analysis.

Applications

- Environmental test chambers
- Engine test cells
- Clean rooms
- Air conditioning and heat exchange coil testing
- Metrology labs

Theory of operation

Chilled mirrors fundamentally measure the dew or frost point temperature by controlling a reflective surface to an equilibrium temperature between dew/frost formation and evaporation and precisely measuring the temperature of the mirror at this point.

The chilled mirror sensors consist of a small polished hexagonal rhodium, or platinum mirror attached to a thermoelectric cooling module (TEC). OptiSonde's servo controller applies current to the TEC, which causes the mirror to cool. The mirror is illuminated with a regulated Gallium Arsenide (GaAs) emitter that transmits light in the infrared spectrum. The light reflected by the mirror is received by a photo detector. When water vapor condenses on the mirror as water or frost (ice crystals), the light received by the photodetector is reduced due to scattering. This results in the servo controller reducing the power, causing the mirror to slightly warm. OptiSonde's control system will modulate the amount of current flowing through the TEC to maintain a temperature where the rate of condensation and evaporation of water molecules and the mass of water on the mirror are constant. The resulting temperature of the mirror is then, by definition, equal to the dew or frost point temperature. A precision four-wire platinum RTD embedded in the mirror measures the temperature. The accuracy of the dew point measurement has been validated to an accuracy of $\pm 0.2^{\circ}\text{C}$ dew/frost point.

Dry bulb temperature is measured with a precise four-wire 100W platinum RTD. The dew/frost point and dry bulb RTD resistance signals are conditioned and amplified by OptiSonde's monitor to display and transmit dew/frost point and temperature. The cardinal measurements of dew/frost point and dry bulb temperature, along with pressure and molecular weight constants, are used to calculate other humidity parameters, such as relative humidity, wet bulb, ppmv, ppmw, absolute humidity, and water vapor pressure values using psychometric equations. The RTD sensor, which is embedded in the chilled mirror, never comes in contact with the process or test environment. The wetted parts consist of the platinum or rhodium mirror, Mylar® or stainless steel vapor barrier and epoxy sealant. The net result is drift free humidity measurement designed to maintain accuracy specifications for many years.

Key benefits

- Compact and rugged design for easy installation and durability
- Built-in data logger provides ability to record historical data
- Sensor conveniently plugs into wall mount chassis for facility monitoring, eliminating the need to run cable
- Sensors may be connected up to 91 m away via cable for remote monitoring
- Displays and transmits in a variety of parameters, such as dew point, relative humidity, dry bulb, wet bulb, absolute humidity, volume ratio, and mass ratio, offering flexibility during operation
- Digital (RS-232) interface for data integrity
- Patented PACER® cycle automatically cleans mirror to ensure measurement integrity
- PanaView™ software transfers data from the meter to a PC for additional storage and enables data to be viewed graphically
- Easy to configure using the front panel for simple operation
- Humidity measurements are traceable to National Institute of Standards and Traceability (NIST)

Chilled mirrors require a nominal flow rate across the mirror to achieve the optimal dew/frost formation and response time. The sensor should either be installed in a duct with moving air or be equipped with a sampling pump. The optimum flow rate is 0.5 to 2.5 SCFH (0.25 to 1.2 L/min). Panametrics provides sampling systems to condition the temperature, regulate the pressure and filter process air before reaching the chilled mirror. Our applications engineers would be pleased to discuss your application in detail and provide a recommendation for the system best suited to your needs.

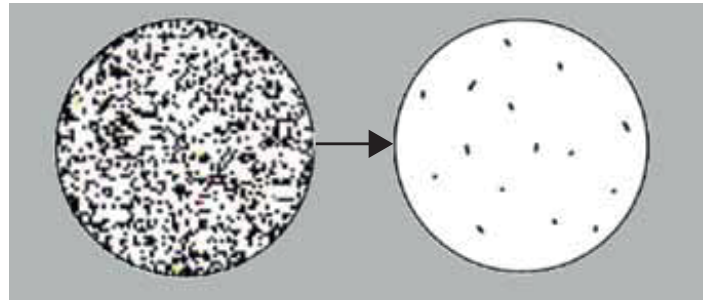
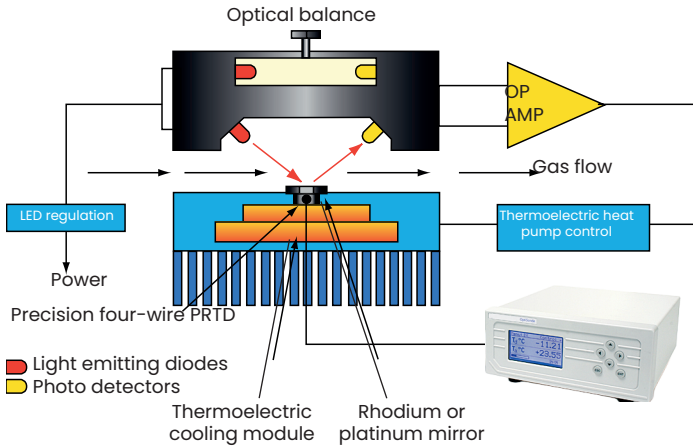

Before PACER cycle

After PACER cycle

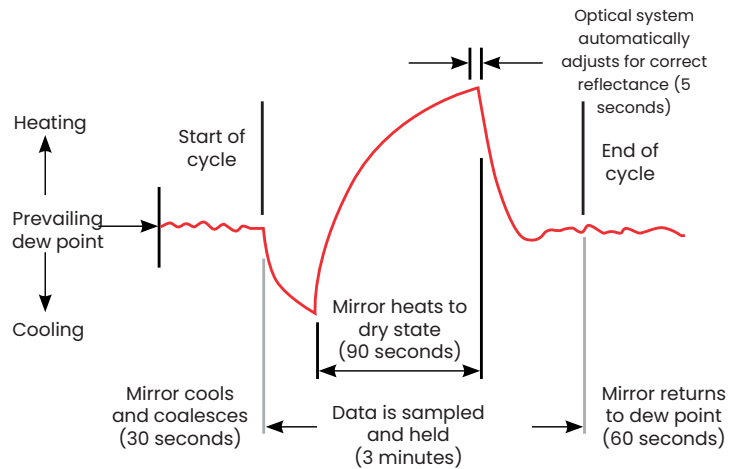

Contamination control and self-cleaning mirrors

For environments where physical contaminants such as dust, oil mist and pollen are present, the use of a sampling system with a filter media is recommended. The filter media must be hydrophobic so as to not absorb or release water vapor into the test stream. Over time the mirror can be etched or pitted by particulates that lead to altering the light scattering characteristics. The mirrors are field replaceable. The standard rhodium mirror may be upgraded to platinum for industrial applications. The two stage sensors also utilize stainless steel wetted surfaces.

PACER® (Program Automatic Error Reduction) is a patented contamination compensation scheme. The PACER cycle may be initiated manually or by programming a timed cycle. The cycle starts by capturing the data (during the PACER cycle a constant reading can be transmitted via the analog outputs) and cooling the mirror well below the dew point such that a thick dew layer forms on the mirror.

The mirror is then rapidly heated. During the heating a significant amount of soluble and some non-soluble contamination is flash evaporated. The contamination left on the mirror tends to aggregate in “dry islands” or “spots” (much like a glass that comes out of a dishwasher). This process leaves approximately 85% of the mirror clean. The light signal received by the photodetector is compared against a reference LED/photodetector and the two signals are “balanced,” effectively negating the effect of the residual contamination left on the mirror.

The PACER cycle works very well, but eventually manual cleaning may be required. All the chilled mirror sensor surfaces are accessible for manual cleaning. Cleaning is a simple process consisting of wiping the mirror with a cotton swab wetted with cleaning solution or distilled water.

Calibration services

Proper calibration is critical to the measurement integrity of your equipment. Comparing and adjusting the output of a device or sensor against a known reference standard ensures accuracy, reliability and repeatability. We provide a single source for initial start-up, programming and verification and for scheduled calibrations. The requirements of your application dictate the frequency of calibration and we will tailor a multi-year contract to your needs.

We perform on-site calibrations that keep your equipment in your facility—minimizing downtime. This is a good alternative if you have more than one piece of equipment. Mail-in service to our modern calibration facilities provides a more controlled environment and NIST traceability.

Technical Specifications

OptiSonde specifications

Power	<ul style="list-style-type: none"> • 100 - 240 VAC, 50 to 60 Hz, 60 watts • 18-32 VDC (bench top only)
Enclosure material	<ul style="list-style-type: none"> • Wall mount: Cast aluminum • Bench top: Aluminum body with plastic front bezel
Dimensions	<ul style="list-style-type: none"> • Wall mount: 26.6 x 20.8 x 11.4 cm (h x w x d) • Bench top: 9.4 x 20.3 x 22.4 cm (h x w x d)
Weight	<ul style="list-style-type: none"> • Wall mount: 2.4 kg • Bench mount: 1.4 kg
Ingress protection rating	<ul style="list-style-type: none"> • Wall mount: IP-65 • Bench top: IP-20
Front panel keys	Rubber function keys—may be locked out via software
Dew point range	Dependent on sensor used
Dew point accuracy	± 0.2°C dew/frost point
Dew point repeatability	0.1°C
Temperature accuracy	±0.15°C
Other humidity parameters	The range and accuracy of absolute humidity (mH ₂ O/v) and relative humidity (e/esat) readings are based on the fundamental dew point and temperature measurements. The range and accuracy of mass (ppmw) and volume (ppmv) ratios are calculated based on the fundamental dew point measurement and pressure and gas molecular weight constants.
Repeatability	0.05°C
Display	Two simultaneous parameters with 0.01°C resolution. "Dew Layer Thickness," "Control," "Alarm" and "Service" indicators
Analog output	Two linear simultaneous parameters. 0/4 to 20 mA (isolated) with 250Ω max load
Alarm	Form C (SPDT) 7 amp, 30 VDC (resistive load)
Digital interface	RS-232
Cooling slew rate	1.5°C/sec

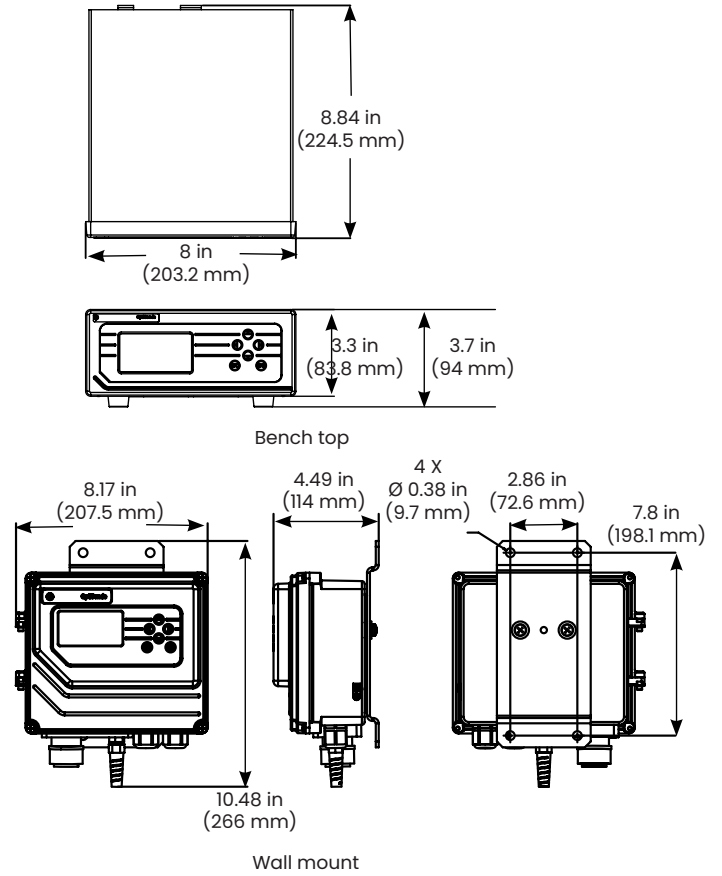

Self cleaning and balancing Via patented PACER cycle. PACER may be programmed to run on an elapsed time or daily timer.

Operating temperature Analyzer: -10°C to 60°C

Data logger Capable of recording eight parameters, time and date for a minimum of 100 days at sample rate of one second.

Operating humidity 0 to 95% RH non-condensing

MTBF Five years of continuous operation

Certifications CE Approval

Electrical I/O Power: AC IEC receptacle for bench top and screw terminal blocks for wall mount. Chilled mirror sensor: keyed connector/cable. Temperature sensor, keyed connector/cable. RS-232: SUB-D-9. Analog outputs: screw terminals

Carrying case Optional hard shell carrying case with die-cut foam for bench top unit and accessories

1111H single stage chilled mirror specifications

Sensing element	Four-wire 1/3 Class A DIN 43760 PRT, 100Ω @ 0°C
Dew/frost point accuracy	± 0.2°C
Depression	45°C at 25°C, 1 atmosphere for standard air
Typical dew point measurement range	-15°C to 25°C Td at 25°C, 1 atmosphere for standard air. (Equivalent to 6-100% RH)
Sample flow rate	0.25 to 1.25 LPM (0.5 to 2.5 SCFH)
Operating temperature	-15°C to 80°C
Operating pressure	0.8 to 15 bar (-3 to 200 psig)
Power	Derived from analyzer
Sensor body	Epoxy-coated aluminum
Filter	PTFE filter optional (standard on 1111H)
Mirror	Rhodium-plated copper (solid platinum optional)
Vapor barrier	Mylar
Sensor wetted material	Epoxy-coated aluminum, rhodium copper, mylar
Electrical connector	MS style multipin keyed connector
Weight	<ul style="list-style-type: none"> • 1.4 kg (1111H) • 1.8 kg (1111H)
Accessories	<ul style="list-style-type: none"> • MB-11: Wall mounting bracket (1111H) • PTFE: PTFE filter • Platinum mirror

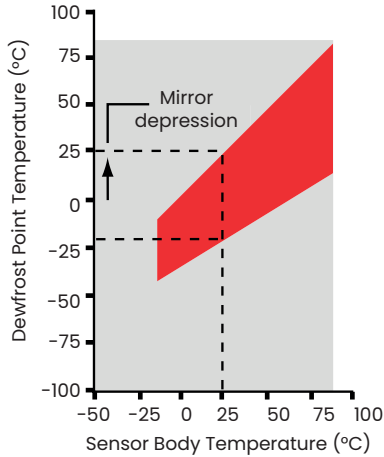
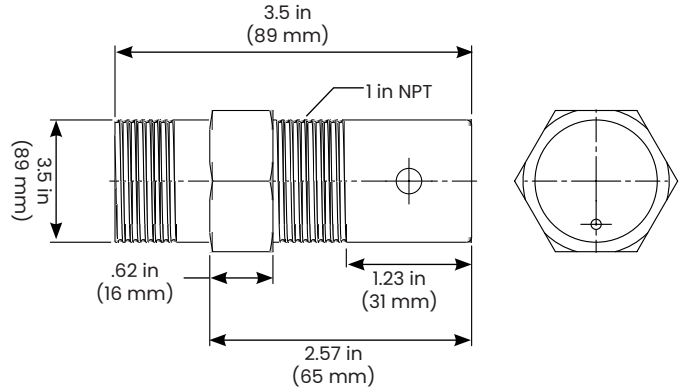

1111 H

D2 two-stage chilled mirror specifications

Sensing element	Four-wire 1/3 Class A DIN 43760 PRT, 100W @ 0°C
Dew/frost point accuracy	± 0.2°C
Depression	65°C at 25°C, 1 atmosphere for standard air
Typical dew point measurement range	-35°C to 25°C Td at 25°C, 1 atmosphere for standard air. (Equivalent to 1 to 100 % RH)
Sample flow rate	0.25 to 1.25 LPM (0.5 to 2.5 SCFH)
Operating temperature	-25°C to 85°C
Operating pressure	1 to 11 bar (0 to 150 psig)
Power	Derived from analyzer
View port	Equipped with illuminated view port that enables observation of mirror
Sensor body	Cast aluminum with 314 SS flow cell
Mirror	Rhodium-plated copper (solid platinum optional)
Vapor barrier	Stainless steel
Sensor wetted material	302, 314, 316 stainless steel, silicone O-ring, BK-7 glass, rhodium-plated copper or platinum mirror aluminum, rhodium copper, mylar, PTFE
Inlet/outlet	0.25 in (6.35 mm) OD tubing fittings
Electrical connector	SUB-D-15
Weight	1.8 kg (4 lb)
Accessories	Platinum mirror

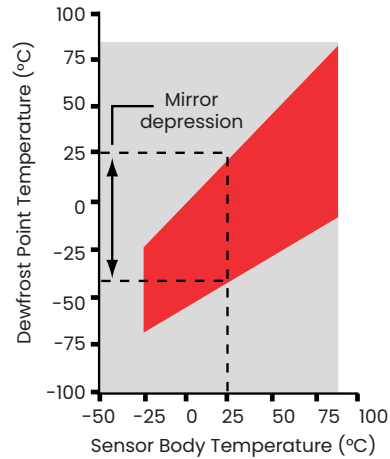
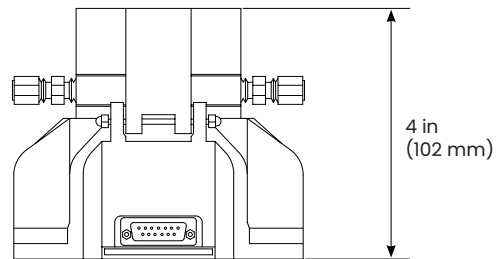
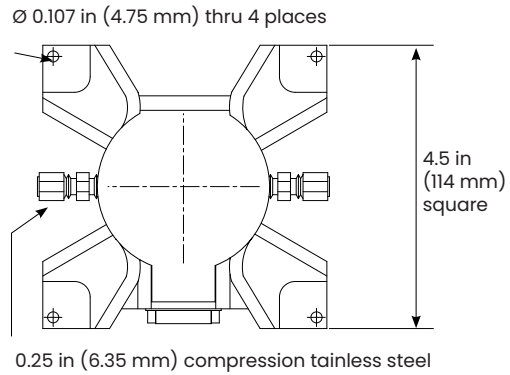

1211H two stage chilled mirror specifications

Sensing element	Four-wire 1/3 Class A DIN 43760 PRT, 100Ω @ 0°C
Dew/frost point accuracy	± 0.2°C
Depression	65°C at 25°C, 1 atmosphere for standard air
Typical dew point measurement range	-35°C to 25°C Td at 25°C, 1 atmosphere for standard air. (Equivalent to 6 to 100% RH)
Sample flow rate	0.25 to 1.25 LPM (0.5 to 2.5 SCFH)
Operating temperature	-25°C to 100°C
Operating pressure	1-21 bar (0 to 300 psig)
Power	Derived from analyzer
Sensor body	Cast aluminum with 314 SS flow cell
Mirror	Rhodium-plated copper (solid platinum optional)
Vapor barrier	Mylar
Sensor wetted material	302, 314, 316 stainless steel, silicone O-ring, rhodium plated copper or platinum mirror
Inlet/outlet	0.25 in (6.35 mm) OD tubing fittings
Electrical connector	MS style multipin keyed connector
Weight	1.8 kg (4 lb)
Accessories	Platinum mirror Stainless steel vapor barrier

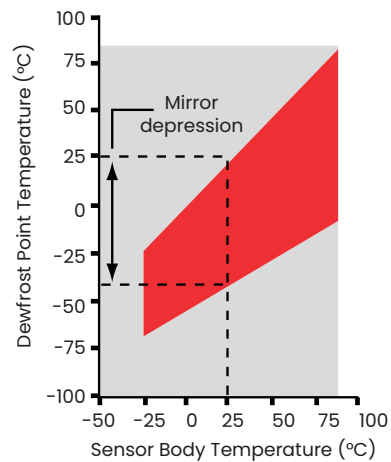
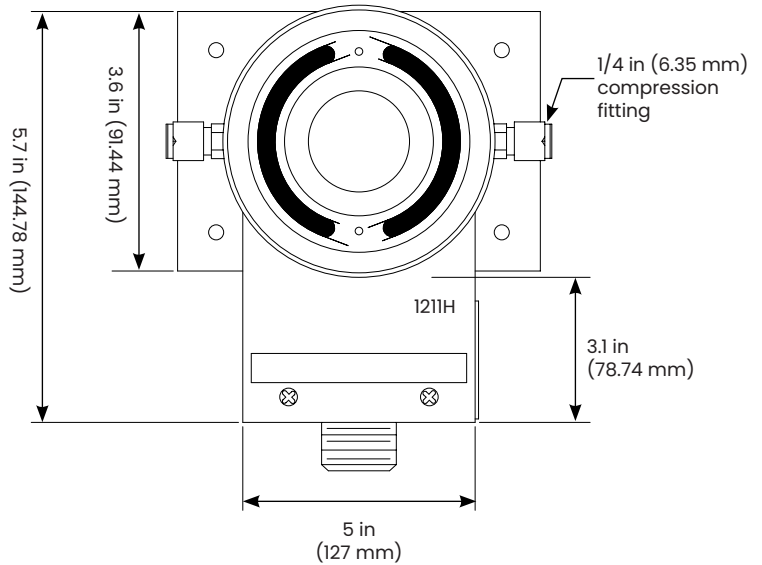

SIM-12 heated two-stage chilled mirror specifications

Sensing element	Four-wire 1/3 Class A DIN 43760 PRT, 100 W @ 0°C
Dew/frost point accuracy	Standard: ±0.2°C
Sensitivity	>0.03°C
Repeatability	±0.05°C
Hysteresis	Negligible
Cooling stages	Two-stage TEC module
Auxiliary cooling	Not applicable
Depression	85°C at 75°C body temperature and atmospheric pressure
Typical measurement range	-10°C to 75°C dew/frost point (Td) in air @ 75°C body temperature in 25°C ambient temperature and atmospheric pressure. Equivalent to 0.7% to 100% RH. Other parameters based on calculations.
Sample flow	0.5 to 5.0 SCFH (0.25 to 2.5 L/min)
Operating temperature	-15°C to 100°C
Heater control	Thermostatically controlled. Set point of 25°C, 40°C, 55°C, 70°C, 85°C and 100°C
Pressure	50 psig (4.5 bar) maximum 100/115/230 VAC, 50/60 Hz, 75 watts
Sensor body	Cast aluminum with 314 stainless steel flow cell
Sensor wetted material	302, 316 stainless steel, silicone o-ring, BK-7 glass, rhodium or platinum mirror
Mirror	Standard: Rhodium plated copper Optional: Solid platinum
Vapor barrier	Mylar (upgradeable to stainless steel)



Electrical connector MS-style multipin connector
IEC receptacle for AC power

Weight 7 lb (3.2 kg) net

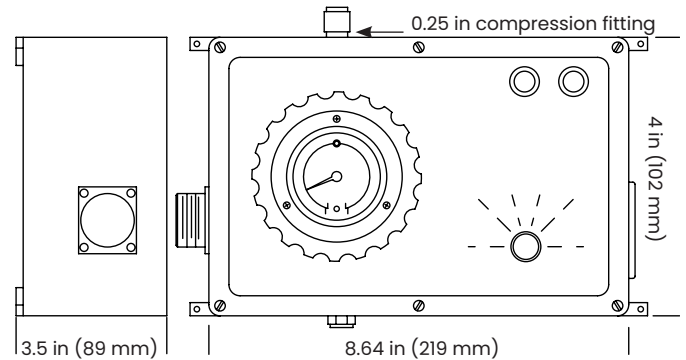

Accessories

- P** Platinum mirror
- X** Enhanced accuracy ±0.27°F (±0.15°C) Td
- S** Stainless steel vapor barrier
- HSS-12** Heated sampling system. SIM-12 heated chilled mirror, SIM-HFT heated filter module and SIM-HFM heated flowmeter mounted on a plate with SIM-HSL heated sample line.

1311-DR four-stage chilled mirror specifications

Sensing element	Four-wire 1/3 Class A DIN 43760 PRT, 100 W @ 32°F (0°C)	
Dew/frost point accuracy	Standard:	±0.2°C
Sensitivity	0.03°C	
Repeatability	±0.05°C	
Hysteresis	Negligible	
Cooling stages	Four-stage TEC module	
Auxiliary cooling	Liquid cooling jacket	
Depression, air cooled	95°C at 25°C and atmospheric pressure cooled	
Depression, liquid cooled	105°C with 15°C cooling water	
Typical measurement range	<ul style="list-style-type: none"> -65°C to 25°C dew/frost point (Td) in air @ 25°C and atmospheric pressure. -75°C to 15°C in liquid-cooled mode with 15°C coolant. Other parameters based on calculations.	
Sample flow	0.5 to 5.0 SCFH (0.25 to 2.5 L/min)	
Operating temperature	0°C to 35°C	
Pressure	300 psig (22 bar) maximum	
Power	100/115/230 VAC, 50/60 Hz, 300 watts	
Sensor body	Cast aluminum with 314 stainless steel flow cell	
Mirror	Standard:	Rhodium plated copper
	Optional:	Solid platinum
Sensor wetted material	302, 316 stainless steel, silicone o-ring, BK-7 glass, rhodium or platinum mirror	
Vapor barrier	Mylar (upgradeable to stainless steel)	



Inlet/outlet 1/4 in (6 mm) OD tubing compression fittings

Electrical connector MS-style multipin connector mates IEC receptacle for AC power

Weight 34 lb (16 kg) net

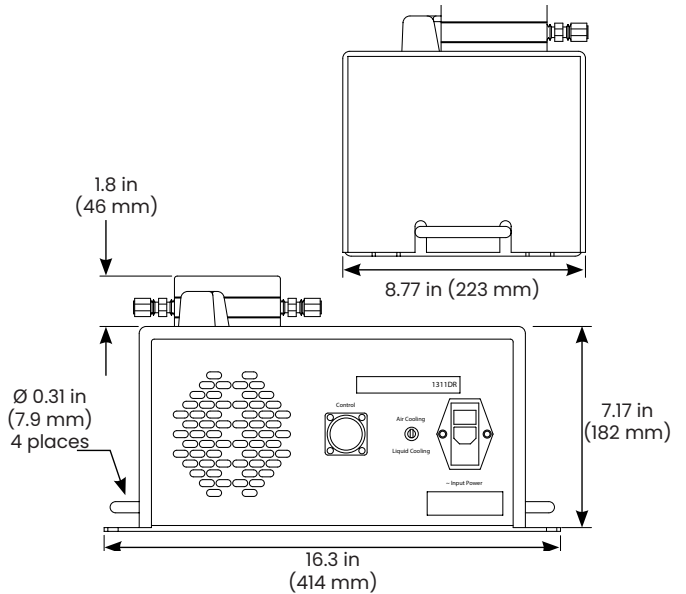

Accessories

- P Platinum mirror
- S Stainless steel vapor barrier

T-100 four-wire PRTD temperature sensor

Sensing element	Four-wire 1/3 Class A DIN 43760 PRT, 100W @ 0°C
Accuracy	0.15°C
Range	-100°C to 100°C
Response time	7 seconds for 25°C to 70°C step change in fluid
Sensor body material	Stainless steel
Cable	PTFE insulation rated to 150°C, 3 m (10 ft) length, spring strain relief
Power	Low voltage derived from analyzer
Weight	0.9 kg (2 lb)

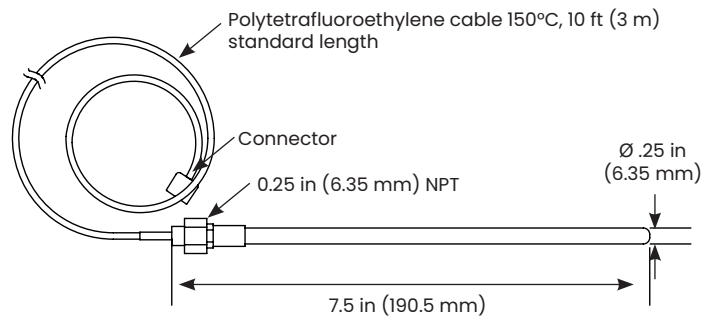

Accessories

PTFE: FILTER for 1111H Sensor

- Hard shell carrying case for benchtop unit with accessories.
- Calibration-multi-year
- Extended warranty

Ordering information

Analyzer	
1	Benchtop
2	Wall mount
Power	
1	100-240 VAC, 50-60 Hz
2	18-32 VDC
Chilled mirror sensor	
0	None
1	1111H single stage sensor, 1" M-NPT fitting
2	1111H single stage sensor. Flange for duct mounting and PTFE filter
3	D2 two stage sensor
4	1211H two stage high temperature and pressure sensor
5	SIM-12H two stage heated sensor. 115 VAC
6	SIM-12H two stage heated sensor. 230 VAC
7	HSS-12H two stage heated sensor and sampling system. 115 VAC
8	HSS-12H two stage heated sensor and sampling system. 230 VAC
9	1311-DR four stage chilled mirror sensor. 100 VAC
A	1311-DR four stage chilled mirror sensor. 115 VAC
B	1311-DR four stage chilled mirror sensor. 230 VAC
Chilled mirror type	
1	Rhodium
2	Platinum
Chilled mirror sensor vapor barrier	
1	Mylar
2	Stainless steel
Analyzer to chilled mirror sensor cable	
0	No cable 1111H fixed to wall mount
1	10 ft standard
2	25 ft
3	50 ft
4	100 ft
5	200 ft
6	300 ft
Temperature sensor	
0	100 affixed to wall mount
1	T-100 w/10 ft cable (standard)
2	T-100 w/25 ft cable
3	T-100 w/50 ft cable
4	T-100 w/100 ft cable
5	T-100 w/200 ft cable
6	T-100 w/300 ft cable

Notes:

1111H sensors are only available with mylar vapor barriers

D2 sensors are only available with stainless steel vapor barriers

Analyzer to sensor cable will be dependent on which analyzer (bench or wall) and sensor is ordered

All systems are standard dew point accuracy $\pm 0.2^{\circ}\text{C}$ Td and temperature $\pm 0.15^{\circ}\text{C}$ Ta

For 1111H affixed to wall mount, you must select 1111H and wall unit

For T-100 affixed to wall mount, you must select the wall analyzer

18-32 VDC power supply is only available on bench top analyzer