



Aurora NOSS

TDLAS moisture analyzer

Aurora NOSS is a modified version of the Aurora analyzer. It is configured to enable installation within customized sampling systems. The Aurora NOSS consists of the laser absorption flow cell, sample pressure and temperature sensors, read-out electronics with local display and keypad interface. The unit is assembled on an epoxy coated or 316 SS plate. All system components are Class 1 Division 1 or ATEX/IECEx Zone 1 certified.

PANA083DS Rev. 5

A sampling system is required to filter contaminants, reduce the pressure of the applied process gas and control the flow rate. In addition, sample-conditioning components such as heaters, valves, flow meters etc., may be applied depending on the specific application. Panametrics' applications engineers can review your application details and design a system to meet your requirements. The Aurora NOSS has the identical functionality, features, and performance as the turnkey Aurora. Please refer to the Aurora product data sheet for additional information.

Dimensions

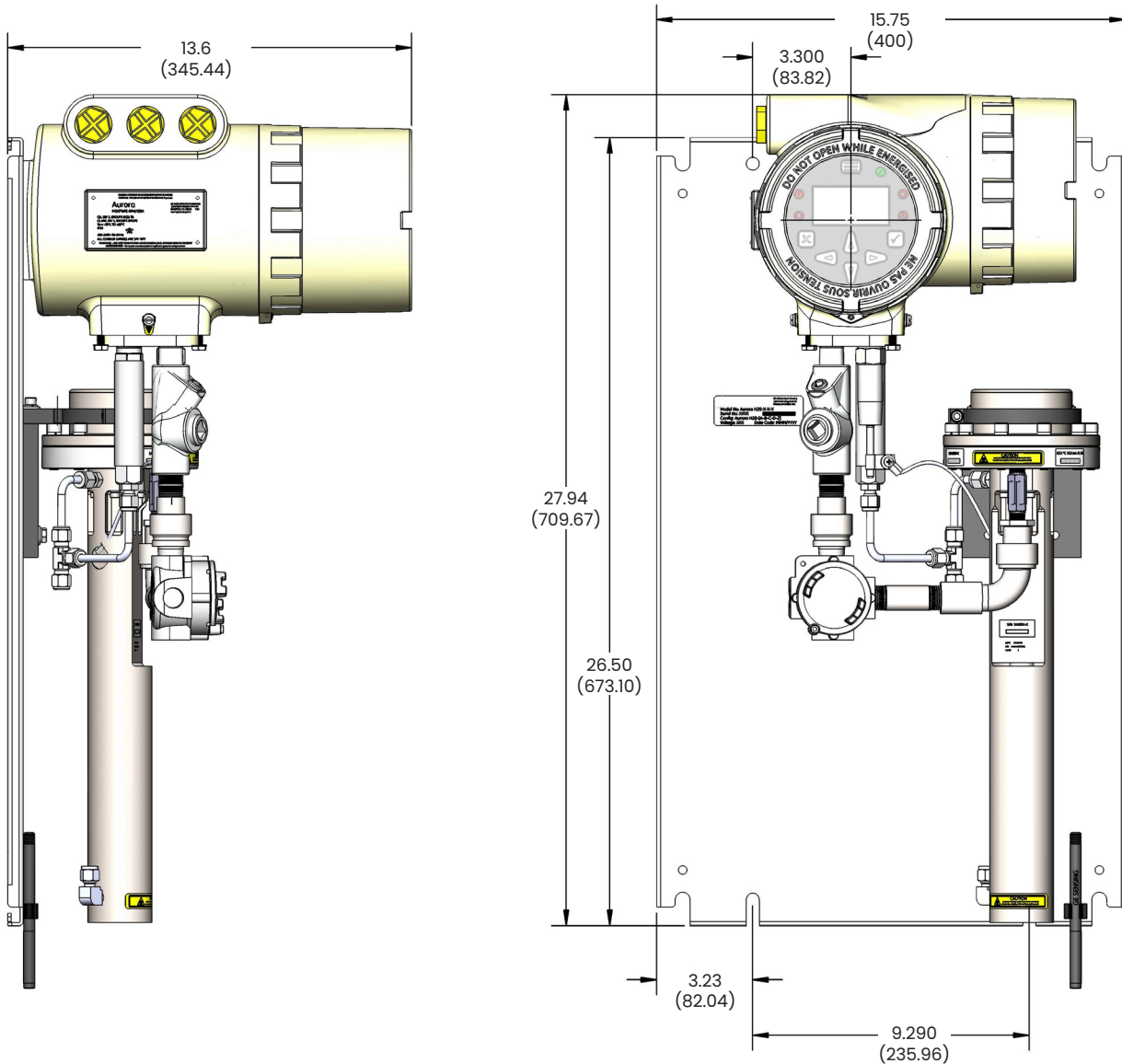

Dimensions in inches (mm)

Technical Specifications

Power

- 100-240 VAC, 50-60 Hz, 10 W
- 18-32 VDC (24 VDC nominal), 10 W

Range

- Parts per million by volume**
- 0 to 5000 ppmv
 - For CO₂ applications: 0 to 1000 ppmv

Dew/frost point -97.1° to 27.3°F (-71.7° to -2.6°C) frost point @ STP of 25°C, 14.696 psia

Process dew/frost point Process or equivalent dew point/frost point by calculation with process pressure signal (4-20 mA) or constant pressure value.
Notes: Readings below 0°C (32°F) are in "frost point" temperature and above 0°C (32°F) are in "dew point" temperature.

Absolute humidity 0.095 to 237 lbs/MMSCF (1.52 to 3,803 mg/m³)

Accuracy

Parts per million by volume ±1% of reading or ±2 ppmv, whichever is greater; for >1000 ppmv ±5% of reading.

For CO₂ applications ±3% of reading or ±5 ppmv

For H₂ recycle applications ±1% of reading or ±2 ppmv (for up to ±5% H₂ and ±1% C₂H₆ variation from nominal calibration composition).

Individual instrument calibrated accuracy conditions provided in Certificate of Conformance. Accuracy of other parameters derived from ppmv.

Repeatability

Parts per million by volume

- ±0.2 ppmv or ±0.1%, whichever is greater.
- For CO₂ applications: ±1.0 ppmv or ±0.5%, whichever is greater.

Other moisture parameters Derived from ppmv

Response time

Optical response < 2 seconds

System response The system response is dependent on the length of sample tubing, sample system components, flow rate and pressure, and the change in moisture concentration.

Operating pressure

Operating sample cell pressure 10 to 25 psia (69 to 172 Pa)

Maximum sample cell pressure 200 psi (1380 kPa)

Notes: Higher pressure available with application of additional sampling system components.

Operating temperature

Operating temperature range -20° to 65°C (-4° to 149°F)

Flowrate

Sample cell flowrate 10 to 60 SLH (0.4 to 2 SCFH); 30 SLH (1 SCFH) nominal
Notes: A fast loop bypass of 5-10x of the sample cell flow rate is recommended.

Display

Backlit LCD Three programmable simultaneous parameters. Alphanumeric status and diagnostic display.

LED indicators Power, laser temperature stability, keypad lockout and faults.

User interface Keypad is programmable "through-the-glass" via magnetic stylus.

I/Os

Analog outputs Three 0/4-20 mA DC (source) with 500-ohm load. User programmable for any parameter and scalable. Complies with NAMUR protocol for analog signals.

Analog inputs Loop powered 4-20 mA input for remote pressure transmitter. Aurora supplies 24 VDC.

Digital interface

Serial ports Two programmable digital communications RS232/RS485 ports. Multidrop capability with assignable address. MODBUS RTU protocol. One ethernet port: Modbus TCP/IP protocol

Enclosure Ingress rating IP-66

Dimensions

Physical See drawing
Notes: The unit is assembled on an epoxy-coated steel plate. A 316 stainless steel plate is available on special order.

Net weight 33.6 kg/74 lbs.

Certifications

United States/Canada cFMus Explosion-proof for Class I, Division 1, Groups B, C, D.

EU and other countries ATEX and IECEx: Ex de IIB+H2 T6 -20°C to +65°C Flameproof with increased safety compartment

European certification CE: Complies with EMC Directive 2004/108/EC, Low Voltage Directive 2006/95/EC and Pressure Directive 97/25/EC for DN/25

Laser

Laser Class 1 product. Conforms to IEC 60825-1. Edition 2.0 Safety of Laser Products.

Notes:

1. Per ATEX and IECEx requirements the laser head assembly of the Aurora H₂O Moisture Analyzer shall be inside a tool secured enclosure with IP20 or better rating to ensure the factory installed laser head assembly bolts are inaccessible from the outside.

Ordering information

The Aurora-NOSS is sold on a customized basis per your particular application. Please contact Panametrics for a price quotation.

ADDVALUE Instruments B.V.
Hoevelakenseweg 185 BIS
3784 WH Terschuur (Barneveld)
Nederland
Telefoon +31(0)342 22 4015
info@addvalueinstruments.com

Join the conversation and follow us on LinkedIn
[linkedin.com/company/panametricscompany](https://www.linkedin.com/company/panametricscompany)

Copyright 2025 by Panametrics LLC. All rights reserved.

PANA083DS_R5 (05/2025)

 **Panametrics**

panametrics.com