



O2.IQ

Oxygen analyzer packaged solution

O2.IQ simplifies and standardizes your options for reliable oxygen measurement in a variety of applications. At the heart of this package is the oxy.iQ analyzer supported by a sample conditioning system purposefully designed to maintain ease of access and functionality in a space conscious housing. Simply mount the O2.IQ, connect to the two terminals and the analyzer is ready for its field calibration. Key highlights include:

- Wall mounted NEMA 4X and IP66 stainless steel package
- Features the oxy.iQ electrochemical analyzer
- Package designed with ease of access including accessibility to sensor cell replacement
- Sample conditioning system provides isolation, filtration, pressure regulation, flow and pressure indication along with a clear window for easy viewing of all readings.

Ordering configuration

The O2.IQ is available in 7 different off-the-shelf configurations covering general purpose to hazardous area requirements, barrier types and metric or imperial fittings. The selection grid highlights the ordering part number which corresponds to the features required for your application and relevant area classification.

Ordering Part No.	Fitting selection		Area classification				Barrier type	
	Imperial	Metric	General purpose	Intrinsically safe global	Class 1 Div 1	Class 1 Div 2 Non incandive	Zener barrier	Galvanic isolator
O2.IQ-CL1-DIV1-Z	✓			✓	✓		✓	
O2.IQ-CL1-DIV1-G	✓			✓	✓			✓
O2.IQ-CL1-DIV2	✓					✓		
O2.IQ-IS-Z		✓		✓			✓	
O2.IQ-IS-G		✓		✓				✓
O2.IQ-GP-I	✓		✓					
O2.IQ-GP-M		✓	✓					

The O2.IQ also requires selection of the appropriate electrochemical OX sensor for the oxy.IQ. Ordering configurations for the OX sensors are as follows and please refer to the sensor interference gases for further information.

Ordering Part No.	Summary
OX-1	Low range ppm measurement, standard background gases
OX-2	Low range ppm measurement, acid background gases
OX-3	Percent measurement, standard background gases
OX-4	Percent measurement, acid background gases
OX-5	Low/mid-range ppm measurement, standard background gases

Oxygen sensor interference gases

Gas	OX-1 and OX-5	OX-2	OX-3		OX-4	
			Continuous	Intermittent (1)	Continuous	Intermittent (1)
H ₂ S	<5 ppm	<10 ppm	0.0005%	0.01%	0.001%	0.1%
SO ₃	<10 ppm	<10 ppm	0.01%	0.1%	0.01%	0.1%
SO ₂	<10 ppm	(3)	0.01%	0.1%	(3)	(3)
HCl	<1000 ppm	(3)	0.1%	1.0%	(3)	(3)
HCN	<1000 ppm	(3)	0.1%	1.0%	(3)	(3)
CO ₂	<1000 ppm	(3)	0.1%	20 &	(3)	(3)
NO ₂	(2)	(2)	(2)	(2)	(2)	(2)
Cl ₂	(2)	(2)	(2)	(2)	(2)	(2)

(1) Recommended maximum exposure 30 minutes, followed by flushing with ambient air for an equal period.

(2) Minimal effect on sensor performance, but produces signal interference of 1:2 ratio for ppm levels only (e.g., 100 ppm NO₂ looks like 200 ppm O₂).

(3) Minimal effect on sensor performance.

Applications

The standard O2.IQ package has been designed with oxygen measurement in natural gas pipelines in mind; however, the package is easily transferrable to a wide range of applications, given its standard sampling conditioning system. The pressure regulation functionality allows for inlet pressures of up to 400 psig (27.5 bar) and reduces to ambient pressure for accurate measurement.

The compact footprint of this stainless-steel package combined with the loop powered oxy.IQ analyzer make it perfect for safe and hazardous area locations. Markets and applications served include:

- Industrial gas production
- Natural gas
- Petrochemical
- Heat treating and annealing
- Inert weld gases
- Gaseous hydrocarbon streams

Application parameters

- Sample gas pressure: 0 - 400 psig (0 - 27.5 Bar)
- Sample gas temperature: 32 to 113°F (0 to 45°C)
- Power requirements: 24 to 28 VDC at 50 mA

Technical Specifications

All installations

Accuracy	<ul style="list-style-type: none"> • ±1% of range at calibration point • ±2% of range at the calibration point for the 0 to 10 ppmv range (OX-1 or OX-2 only)
Repeatability	<ul style="list-style-type: none"> • ±1% of range • ±2% of range for the 0 to 10 ppmv range (OX-1, OX-2 only)
Resolution	±0.1% of range
Linearity	<ul style="list-style-type: none"> • ±2% of range (OX-1, 2, 3, 5) • ±5% of range (OX-4)
O₂ Sensor operating temperature	32 to 113°F (0 to 45°C)
Sample pressure	Max inlet pressure 400 psig (27.5 barg) vented to atmospheric
Atmospheric pressure effect	±0.13% of reading per mmHg (directly proportional to absolute pressure). During calibration, pressure and flow must be kept constant.
Process connection	1/4 in./6 mm compression tube fittings inlet and outlet
Dimensions	10.0 x 8.0 x 5.32 in (273.1 x 203.2 x 135 mm)
Weight	15.0 lb (6.8 kg)
Sample flow rate	1.0 SCFH (500 cc/min) recommended for process units

Electrical classification certification

- Intrinsically safe**
- USA/Canada
 - IS for Class I, Groups A, B, C, D, T4
 - AEx ia IIC T4
 - ATEX and IECEx
 - Ex ia IIC Ga T4 Tamb -20 to 60°C
- IS package, non-incendive without use of Zener barrier or galvanic isolator:
- USA/Canada: Class I, Div 2, Groups A, B, C, D: T4

European compliance Complies with EMC directive 2004/108/EC

User-selectable measurement range and corresponding sensor

Oxygen content	OX-1 and OX-2	OX-3 and OX-4	OX-5
0 to 10 ppmv	✓		
0 to 20 ppmv	✓		
0 to 50 ppmv	✓		
0 to 100 ppmv	✓		✓
0 to 200 ppmv	✓		✓
0 to 500 ppmv	✓		✓
0 to 1,000 ppmv	✓		✓
0 to 2,000 ppmv	✓		✓
0 to 5,000 ppmv	✓		✓
0 to 10,000 ppmv	✓		✓
0% to 1%	✓	✓	✓
0% to 2%		✓	
0% to 5%		✓	
0% to 10%		✓	
0% to 25%		✓	
0% to 50%		✓	

Installation options

**Class 1 Div 1/Zone 0
Global intrinsically safe**

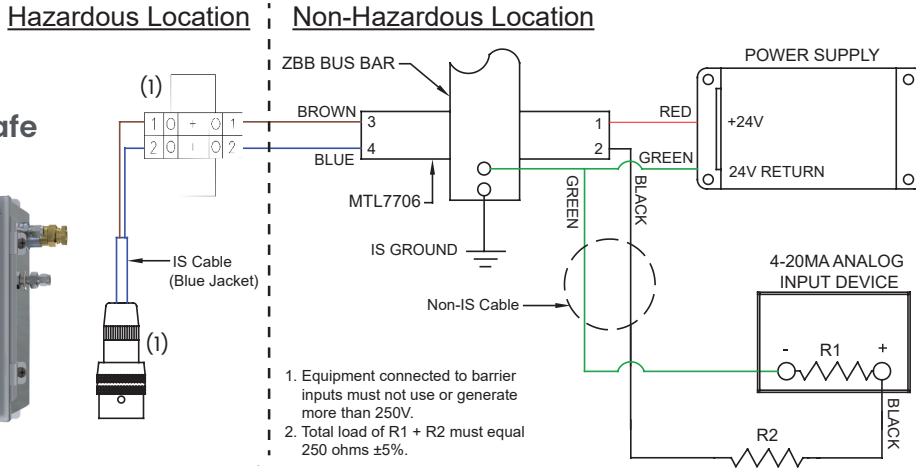

Class 1 Div 2 - Non incendive

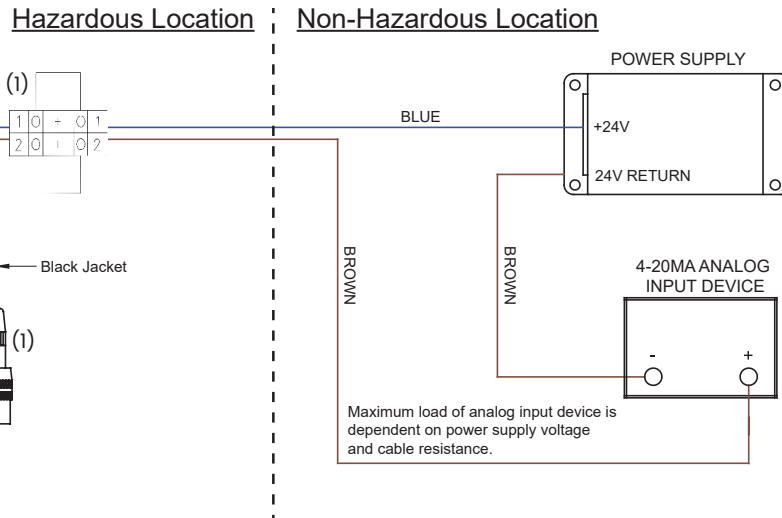

General purpose

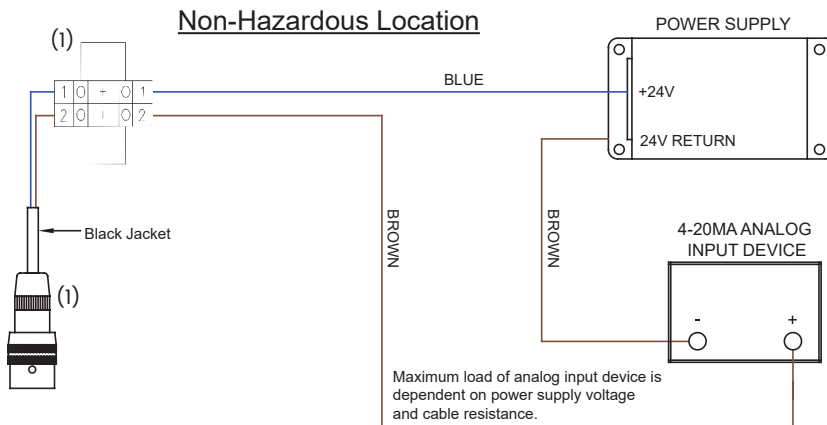

Note: Wiring to integrated terminal strip to be completed at installation site. oxy.IQ connection cable ships separately.

(1) Terminal strip and oxy.IQ connector are internal of the O2.IQ housing. Shown externally for illustration purposes only.

Start up procedure

Initial setup

- Ensure external wiring is securely connected to the terminal strip provided in the O2.IQ and that the oxy.IQ cable is securely fastened at the back of the transmitter and wired into the terminal blocks provided. Pay special attention to barrier installation and wiring if in hazardous area. (See oxy.IQ manual Section 2.2)
- Referring to section 2.3 of the oxy.IQ user manual install the electrochemical cell into the oxy.IQ
- Follow the procedure set out in Sections 3.3.1 – 3.3.3 to set up and perform initial air calibration of the unit
- On completion of initial setup, insert the oxy.IQ into its manifold and ensure it is securely mounted in the O2.IQ sample handling system

Span calibration

- Check that the needle valve (4) is fully closed and that the pressure regulator (2) is backed out by rotating anti-clockwise
- Slowly open the needle valve to allow any trapped pressure and gas to vent to the outlet in the event the unit was in use previously and was shut down for an extended period
- Switch the 3-way selection valve (1) to point in the direction of calibration inlet and attach the calibration gas to the calibration gas inlet port
- Allow calibration gas to flow into the O2.IQ and slowly turn the pressure regulator clockwise until the pressure gauge (3) reads 1-2 psig. Crack open the needle valve and monitor the flow rate on the rotameter (7) and pressure on the pressure gauge
- Slowly adjust the needle valve until a steady flow rate of 1.0 SCFH (500 cc/min) is reached
- Adjust until a steady flow rate of 1.0 SCFH (500 cc/min) and a pressure of 0 psig (14.7 psia) is achieved
- Carry out span calibration as per Section 3.3.4 of the oxy.IQ manual
- When calibration is complete, switch the 3-way selection valve to the central block position and fully close in the needle valve while backing out the pressure regulator by turning anti-clockwise

Bringing process gas online

- Check that the needle valve is in the closed position and switch the 3-way selection valve to point in the direction of the process inlet connection
- With the process gas flowing to the system, slowly turn the pressure regulator clockwise until the pressure gauge reads 1-2 psig. Open the needle valve and monitor the flow rate on the rotameter and pressure on the pressure gauge
- Slowly adjust the needle valve until the flow rate is steady at 1.0 SCFH (500 cc/min)

Shut down procedure

- Slowly shut the needle valve until the flow rate on the rotameter reads zero flow
- Switch the 3-way selection valve to the block position, isolating the process gas
- Re-open the needle valve to allow any trapped process pressure to vent to the outlet
- Close the needle valve back in as added protection against process gas pass through during shut down or maintenance periods

O2.IQ Diagram

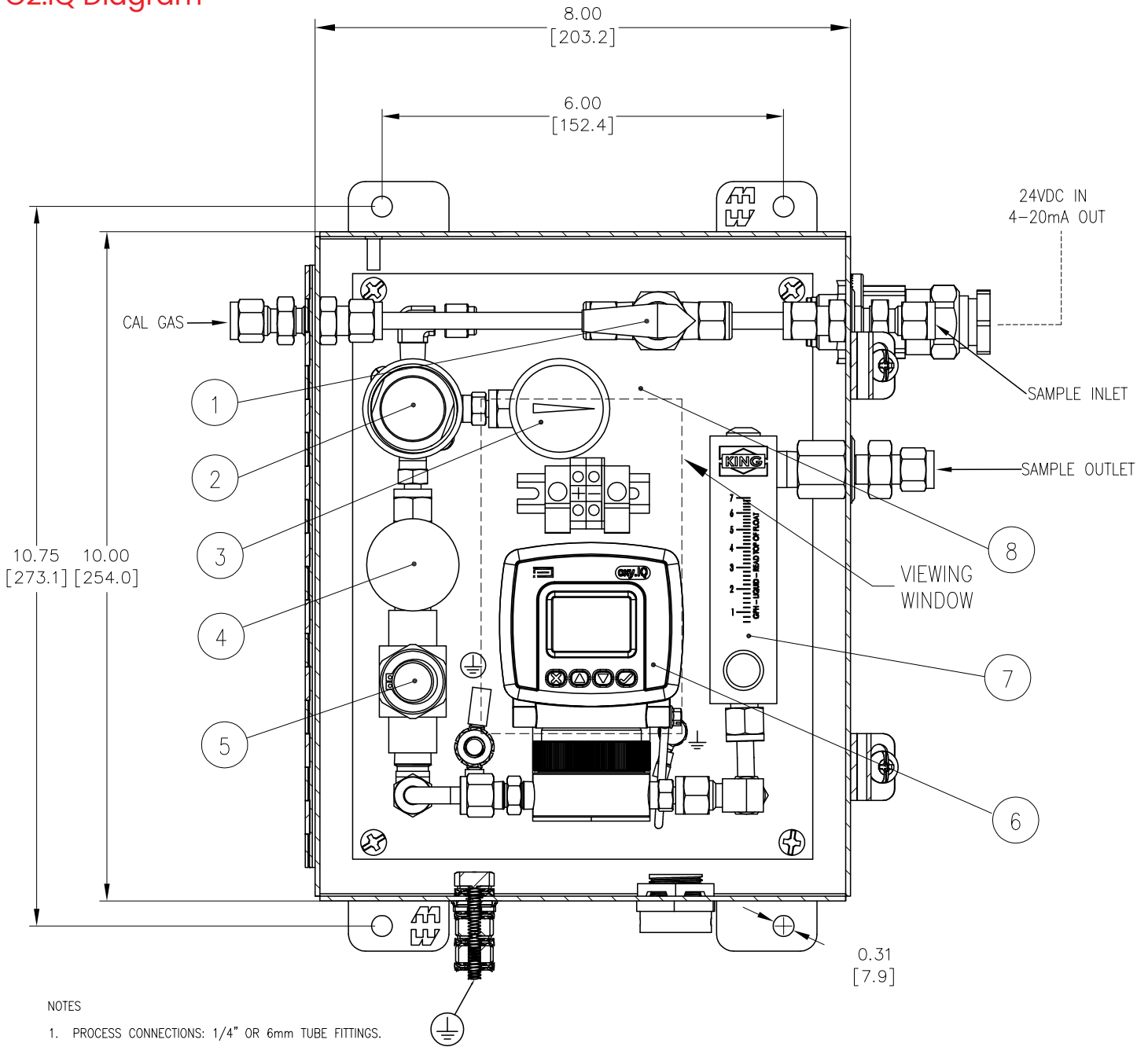

NOTES

1. PROCESS CONNECTIONS: 1/4" OR 6mm TUBE FITTINGS.
2. DIMS : INCH [MM]
3. APPROX WEIGHT : 20LBS [9KG]
4. SIGNAL CONNECTIONS : 1/2" NPTF HUB WITH CABLE GLAND (IMPERIAL VERSION)
M20 CABLE GLAND (METRIC VERSION)
5. ENCLOSURE DEPTH : 5.32 [135]
6. COMPONENTS SELECTED FOR : CLASS I, DIV.1, GROUPS A-D, T4 (CL1-DIV1 VERSION)
CLASS I, DIV.2, GROUPS A-D, T4 (CL1-DIV2 VERSION)
ATEX/IECEx ZONE 0 IIC T4 (IS VERSION)
GENERAL PURPOSE AREA (GP VERSION)
7. AMBIENT TEMP: 33°F to 125°F (1°C to 52°C)
8. AVAILABLE VERSIONS:
O2.IQ-CL1-DIV1-Z : HAZARDOUS AREA, 1/4" TUBE FITTINGS, ZENER BARRIER
O2.IQ-CL1-DIV1-G : HAZARDOUS AREA, 1/4" TUBE FITTINGS, GALVANIC ISOLATOR
O2.IQ-CL1-DIV2 : HAZARDOUS AREA, 1/4" TUBE FITTINGS
O2.IQ-IS-Z : HAZARDOUS AREA, 6mm TUBE FITTINGS, ZENER BARRIER
O2.IQ-IS-G : HAZARDOUS AREA, 6mm TUBE FITTINGS, GALVANIC ISOLATOR
O2.IQ-GP-I : GENERAL PURPOSE 1/4" TUBE FITTINGS
O2.IQ-GP-M : GENERAL PURPOSE 6mm TUBE FITTINGS

BILL OF MATERIAL

ITEM	DESCRIPTION	QTY
1	3 WAY BALL VALVE 316SS	1
2	PRESSURE REGULATOR	1
3	PRESSURE GAUGE	1
4	NEEDLE VALVE 316SS	1
5	7 MICRON FILTER 316SS	1
6	oxy.IQ OXYGEN TRANSMITTER	1
7	ACRYLIC FLOWMETER	1
8	304SS ENCLOSURE WITH PAINTED PLATE RAL6033	1

Notes

1. The O2.IQ will ship with a standard oxy.IQ cable in separate packaging. This offers the end user the capability of wiring directly to their associated equipment if the terminal strip is not required. All wiring should be carried out in accordance with the wiring schematic shown and for the appropriate area classification. Responsibility for the quality of workmanship will be with the end user.
2. The O2.IQ is a robust package with many potential applications. As with all analyzers however, it has certain limitations beyond which could impact on the reliability of measurement and safety. If any question remains around the suitability of the O2.IQ for a particular application then Panametrics are happy to assist with our specialist team of application engineers to support customers in their selection process.
3. While the O2.IQ is a packaged solution which is ordered under a single part number, the electrochemical oxygen sensor must be ordered separately. The selection of the OX sensor which is most suitable for the application should be done in accordance with the selection table included in this datasheet and/or in consultation with Panametrics sales support. The electrochemical sensors which are determined by the OX preface will be shipped as dangerous goods which is standard procedure for all electrochemical sensors.

ADDVALUE Instruments B.V.
Hoevelakenseweg 185 BIS
3784 WH Terschuur (Barneveld)
Nederland
Telefoon +31(0)342 22 4015
info@addvalueinstruments.com

Join the conversation and follow us on LinkedIn
[linkedin.com/company/panametricscompany](https://www.linkedin.com/company/panametricscompany)

Copyright 2023 by Panametrics LLC. All rights reserved.

PANA090DS_R11 (04/2023)

 **Panametrics**

[panametrics.com](https://www.panametrics.com)